

Transportation Impact Study

PROPOSED RESIDENTIAL DEVELOPMENT

55 Eagle Street
Town of Newmarket, ONTARIO

February 2021
Project No: NT-20-026

520 Industrial Parkway South, Suite 201
Aurora ON L4G 6W8

Phone: 905-503-2563
www.nexttrans.ca

nexttrans
CONSULTING ENGINEERS

NextEng Consulting Group Inc.

February 9, 2021

Mr. Frank Orsi
Millford Development Ltd.
PO Box 215
Newmarket ON, L3Y 4X1

**Re: Transportation Impact Study
 Proposed Residential Development
 55 Eagle Street, Town of Newmarket
 Our Project No. NT-20-026**

Nexttrans Consulting Engineers (a Division of NextEng Consulting Group Inc.) is pleased to present the enclosed Transportation Impact Study for the above noted site in support of Official Plan Amendment and Zoning By-law Amendment Applications.

The subject property is located at 55 Eagle Street, in the Town of Newmarket. The proposed development consists of 53 townhouse units, 20 back-to-back townhouse units and 1 triplex house (3 units), for a total of 76 dwelling units. A total of 126 vehicle parking spaces will be provided. As part of the proposed development, one full movement access and one Right-In Right-Out access will provide via Eagle Street.

The transportation study concludes that the proposed development can adequately be accommodated by the existing transportation network, existing YRT/Viva services, as well as the Transportation Demand Management measures and incentives recommended in this report.

We trust the enclosed sufficiently addresses your needs. Should you have any questions, please do not hesitate to contact the undersigned.

Yours truly,

Nexttrans Consulting Engineers
A Division of NextEng Consulting Group Inc.

Prepared by:



Sam Nguyen, Dipl.
Transportation Analyst

Approved by:



Richard Pernicky, MITE
Principal

Issues and Revisions Registry

Identification	Date	Description of issued and/or revision
Final Report	February 9, 2021	For Client Submission

EXECUTIVE SUMMARY

Nexttrans Consulting Engineers (A Division of NextEng Consulting Group Inc.) was retained by Millford Development Ltd. (the 'Client') to undertake a Transportation Impact Study in support of Official Plan Amendment and Zoning By-law Amendment Applications. The subject property is located at 55 Eagle Street, in the Town of Newmarket.

Proposed Development

The development proposal consists of 53 townhouse units, 20 back-to-back townhouse units and one triplex house (3 units), in total of 76 dwelling units.

Proposed Development Access

As part of the proposed development, one full movement and one Right-In Right-Out access are provided via Eagle Street.

Capacity Analysis

The proposed development is expected to generate:

- 36 total new two-way trips (8 inbound and 28 outbound) during the weekday morning and 46 total new two-way trips (29 inbound and 17 outbound) during the afternoon peak hours, respectively;
- 3 total new two-way transit trips (1 inbound and 2 outbound) during the weekday morning and 0 total new two-way transit trips (0 inbound and 0 outbound) during the afternoon peak hours, respectively;
- 27 total new two-way auto trips (6 inbound and 21 outbound) during the weekday morning and 38 total new two-way auto trips (24 inbound and 14 outbound) during the afternoon peak hours, respectively;
- 4 total new two-way active trips (1 inbound and 4 outbound) during the weekday morning and 1 total new two-way auto trips (1 inbound and 0 outbound) during the afternoon peak hours, respectively.

Auto Mode Assessment

Based on the intersection analysis, under the existing, future background and future total, all intersections considered are expected to operate at acceptable levels of service.

The analysis indicates that the proposed accesses via Eagle Street are expected to operate at acceptable levels of service with minimal delays or queues. No improvement to the existing or planned street system would be required to accommodate the proposed development.

Active Transportation Mode Assessment

Walking

Currently, there are sidewalks on both sides of Yonge Street and Eagle Street in the vicinity of the proposed development. No improvements are necessary to accommodate the proposed development. The proposed development will provide internal sidewalks connecting to Eagle Street for pedestrian activity, as well as to support a direct connection to the Yonge Viva Stop.

Cycling

Currently, there is a shared roadway along Eagle Street. It is our understanding that the Yonge Transit Rapid Way Project created the dedicated bicycle lane on Yonge Street which will connect to a larger cycling system that includes other cycling facilities in the area, as defined in the York Region Transportation Master Plan.

Transit Mode Assessment

The analysis indicates that the transit passenger demands generated by the proposed development per transit vehicle is very low (less than one passenger per transit vehicle). As such, the proposed development's impact on transit service is negligible and no improvements are required, even if passengers bunch together during a few 15-minute time intervals within the peak hours. The assessment concludes that the demand per transit vehicle is low and can be accommodated without the need for additional transit vehicles or improvements during both the morning and afternoon peak hour.

It should be noted that the Yonge Transit Rapid way was recently completed and opened for service on January 5th 2020. As such, ridership data will most likely change. The Rapid Transit way is expected to increase transit usage of the overall system, which has already been planned for. However, the proposed development is not of sufficient scale to create a noticeable impact on the transit service.

Vehicle Parking Review

Based on the Town of Newmarket Zoning By-law 2010-40, the proposed development requires a total of 133 parking spaces (114 spaces for residents and 19 spaces for visitors). It is to our understanding that the proposed development will provide a total of 126 parking spaces (91 spaces for residents and 35 spaces for visitors) through driveways for each townhome unit and shared site parking accommodating triplex and visitors, which presents a technical shortfall of 23 parking spaces for residential parking, and surplus of 16 visitor parking.

NexTrans has also reviewed the Town of Newmarket Urban Centres Zoning By-law 2019-06 in order to support the York Region Transportation Master Plan (2016), as well as York Region Transit's (YRT/Viva) 2016-2020 Strategic Plan, as reducing single-auto trip to and from the planning development and encouraging residents to use public transit and other alternative transportation modes, and the subject site is located adjacent to the Zoning Area and Yonge Transit Rapidway amenity, we recommend this Zoning By-law with lower parking rates for the proposed development.

Based on the Town's Zoning By-Law 2019-06, a total of 85 parking spaces would be required for the proposed development. It is our understanding that the proposed development will provide a total of 126 vehicle parking spaces (including 91 parking spaces for residents and 35 parking spaces for visitors) through driveways for each townhome unit and shared site parking for the triplex and visitors, which meets this By-law requirement.

Transportation Demand Management Measures and Incentives

The TDM measures and incentives related to the proposed development have been assessed and recommended in Section 9 of this report to support transit and active transportation, and to meet the objectives and requirements of the York Region Transportation Mobility Plan Guideline.

Loading Requirement

The proposed development will use private garbage pick up on the curb side of the private road.

The AutoTURN analysis demonstrates that a typical garbage truck and fire truck can maneuver within the designed route, internal roadway and site accesses via Eagle Street with no conflict. Additionally, a moving truck under 12.0-meter length is able to access the subject site.

Study Recommendations

Based on the assessment, our report recommends that:

- The proposed development implements the TDM measures and incentives identified in this report to support active transportation and transit and to reduce the numbers of single-occupant-vehicle trips to and from the proposed development;
- The proposed development provides internal shared pedestrian and cycling connections from the proposed development to Eagle Street where appropriate;
- No improvement to the existing or planned street system would be required to accommodate the proposed development.

TABLE OF CONTENTS

1.0	INTRODUCTION	1
2.0	EXISTING TRAFFIC CONDITIONS	2
2.1.	Existing Road Network	2
2.2.	Existing Active Transportation Network	3
2.3.	Existing York Region Transit (YRT) System	4
2.3.	Existing Traffic Volumes	7
2.4.	Existing Traffic Assessment	8
3.0	TRANSPORTATION PLANNING CONTEXT IN THE AREA	8
3.1.	Land Use Context	8
3.2.	Transportation Planning Context	9
4.0	FUTURE BACKGROUND CONDITIONS	9
4.1.	Analysis Horizon	9
4.2.	Future Background Corridor Growth	9
4.3.	Background Development Applications	9
4.4.	Future Background Traffic Assessment	9
5.0	SITE TRAFFIC	11
5.1.	Proposed Development	11
5.2.	Modes of Travel Assessment in the Area	11
5.3.	Site Trip Generation	11
5.4.	Site Trip Distribution and Assignment	12
6.0	FUTURE TOTAL TRAFFIC CONDITIONS	13
6.1.	Future Total Traffic Assessment for Auto Mode	13
6.2.	Pedestrian Mode Assessment	14
6.3.	Transit Mode Assessment	15
7.0	SITE PLAN REVIEW	15
8.0	PARKING ASSESSMENT	16
8.1.	Vehicle Parking Requirement	16
9.0	TRANSPORTATION DEMAND MANAGEMENT	16
10.0	CONCLUSIONS / FINDINGS	17
10.1.	Study Conclusions	17
10.2.	Study Recommendations	18

LIST OF FIGURES

- Figure 1 – Proposed Development Location
- Figure 2 – Proposed Concept Site Plan
- Figure 3 – Existing Lane Configuration and Traffic Control
- Figure 4 – Existing Active Transportation Network in the Study Area
- Figure 5 – Existing Transit Network in the Area
- Figure 6 - Yonge Transit Rapid Way
- Figure 7 – Existing Traffic Volumes
- Figure 8 – 2028 Future Background Traffic Volumes
- Figure 9 – Site Traffic Volumes
- Figure 10 – 2028 Future Total Traffic Volumes

LIST OF TABLES

- Table 1 – Existing Levels of Service for Signalized Intersections
- Table 2 – Background Developments in the Area
- Table 3 – 2028 Future Background Levels of Service
- Table 4 – Modes of Travel based on 2016 TTS Data for Traffic Zones 2612,2613,2614,2615
- Table 5 - Site Total Trip Generation for Current Development Proposal
- Table 6 – Trip Distribution for Residential Component
- Table 7 – Site Trip Distribution
- Table 8 – 2028 Future Total Levels of Service
- Table 9 - Transit Level of Service Summary
- Table 10 – Town of Newmarket Urban Centres Zoning By-law 2019-06 Vehicle Parking Requirements
- Table 11 - Recommended TDM Measures for the Proposed Development

APPENDICES

- Appendix A – Existing Traffic Data
- Appendix B – Existing Traffic Level of Service Calculations
- Appendix C – Historical Traffic Count Analysis
- Appendix D – Background Developments
- Appendix E – Future Background Traffic Level of Service Calculations
- Appendix F – 2016 TTS Data Extraction
- Appendix G – Future Total Traffic Level of Service Calculations

1.0 INTRODUCTION

Nextrans Consulting Engineers (A Division of NextEng Consulting Group Inc.) was retained by Millford Development Ltd. (the 'Client') to undertake a Transportation Impact Study in support of Official Plan Amendment and Zoning By-law Amendment Applications for a residential development. The subject property is located at 55 Eagle Street, in the Town of Newmarket.

The location of the proposed development is illustrated in Figure 1.

Figure 1 – Proposed Development Location

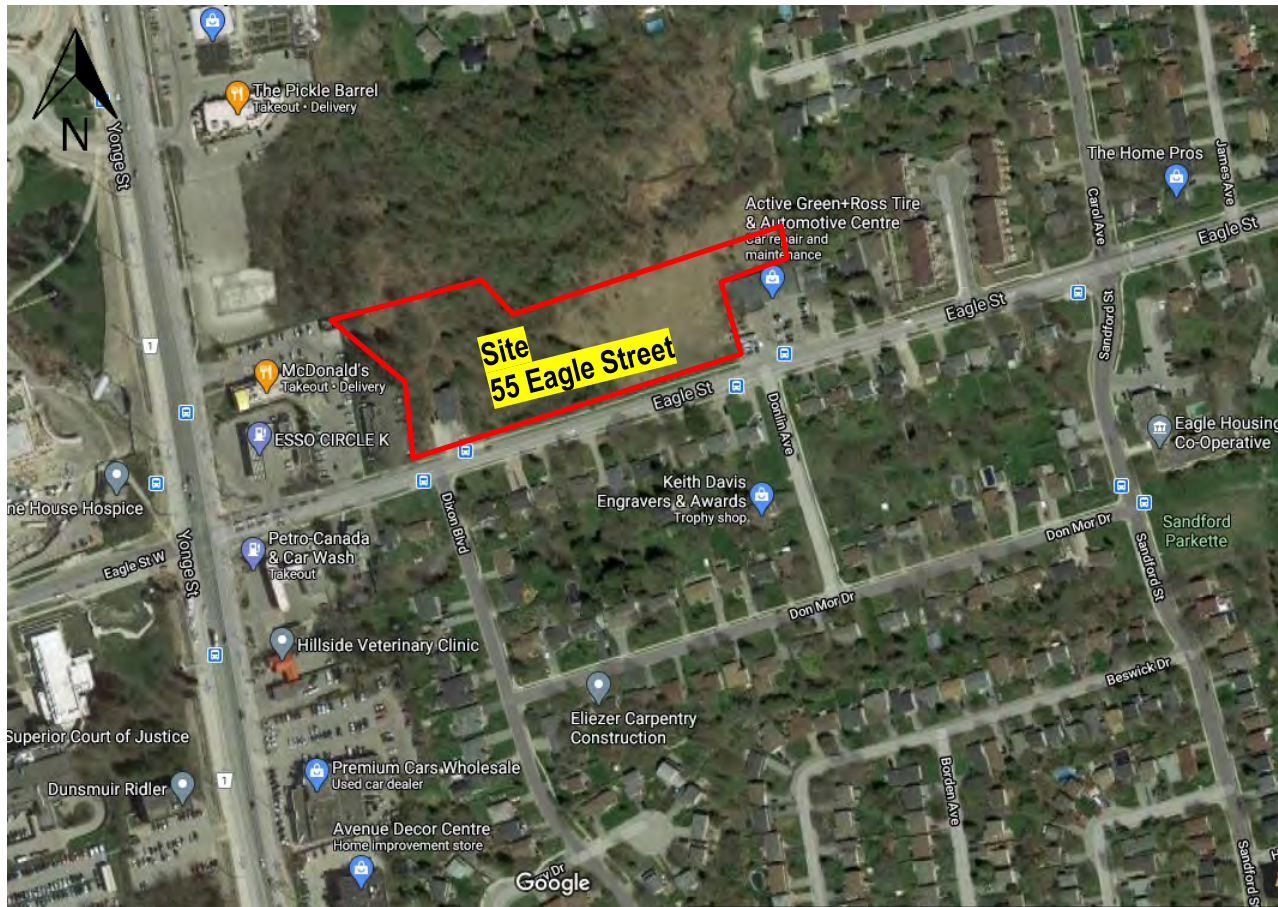

Source: Google Map

The development proposal is for approximately 53 townhouse units, 20 back-to-back townhouse units and 1 triplex house (3 units) in total of 76 dwelling units, to be confirmed through Site Plan Application. One full movement access and one RI-RO access via Eagle Street are proposed.

The proposed development will provide a total of 126 vehicle parking spaces (91 spaces for resident and 35 spaces for visitor) through driveways for each townhouse unit and shared site parking for the triplex house and visitors.

Figure 2 illustrates the proposed development site plan.

Figure 3 – Existing Lane Configuration and Traffic Control

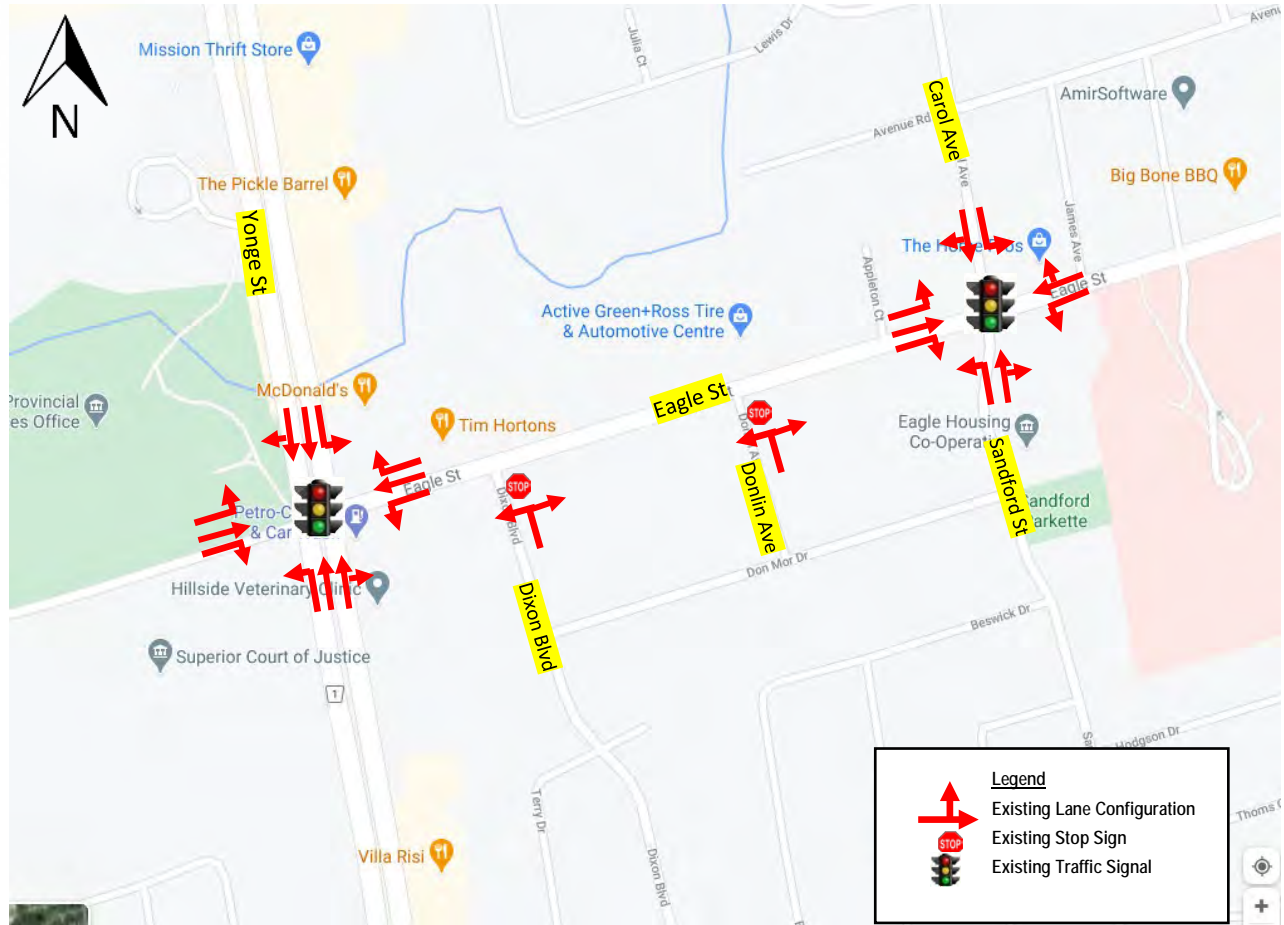

Source: Google Map

2.2. Existing Active Transportation Network

Sidewalk

Currently, there are sidewalks located on both side of Yonge Street and Eagle Street adjacent to the proposed development, no improvements are necessary for the existing public right of ways to accommodate the proposed development. Appropriate suggestions will be provided in later sections of the report that will speak to the internal site design and pedestrian requirement as part of the proposed development.

Bicycle Facility

Currently, there is a shared roadway lane along Eagle Street and dedicated bicycle facility on Yonge Street as part of the Yonge Street Transit Rapidway project, which connects to the larger cycling system in the area.

The proposed development provides pedestrian and cycling connection (internal sidewalks and driveways directly) to Eagle Street, and direct connection to the Viva Station at Yonge Street.

Figure 4 illustrates the existing active transportation network in the study area.

Figure 4 – Existing Active Transportation Network in the Study Area

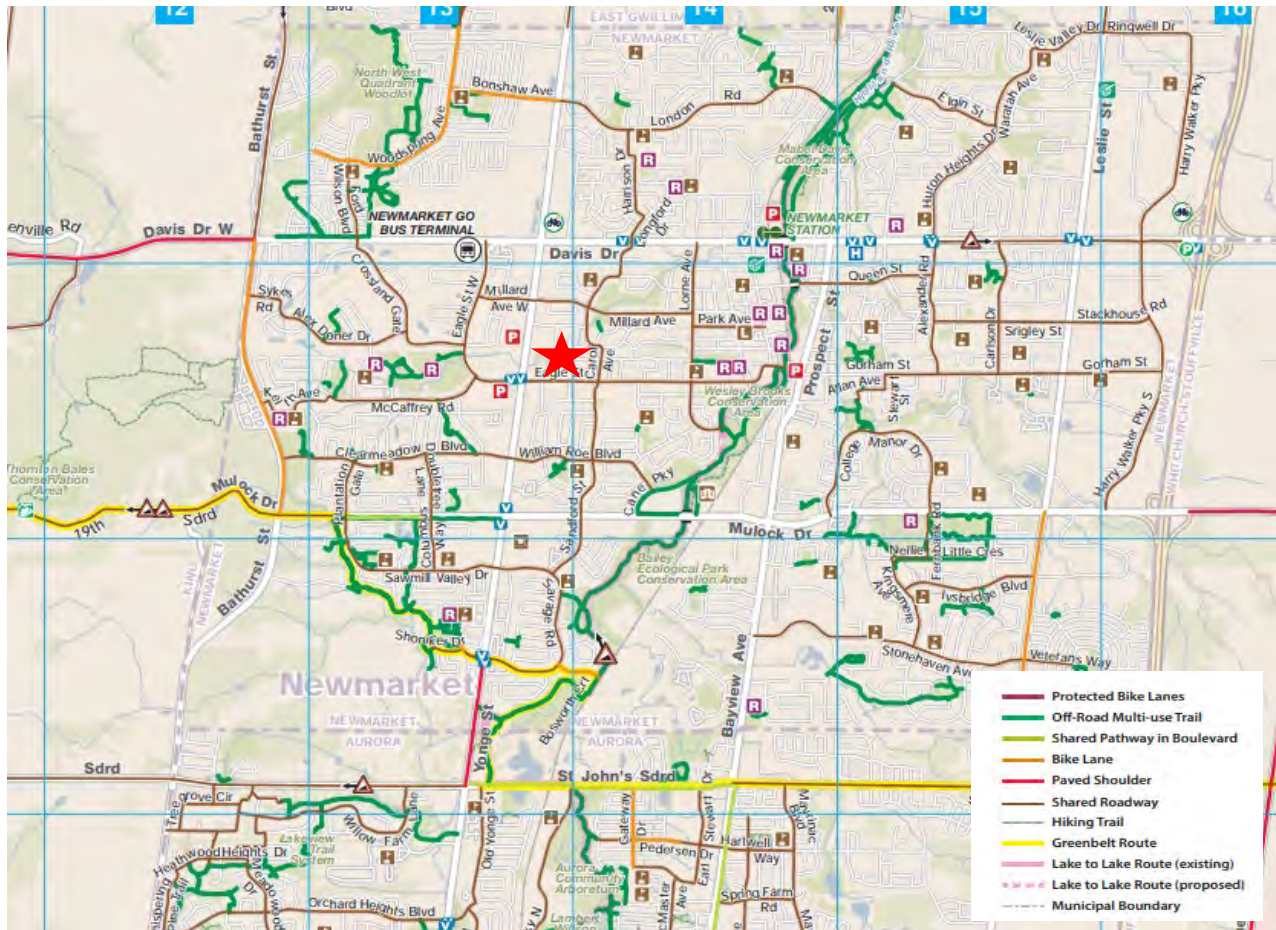

Source: York Region Cycling Map

2.3. Existing York Region Transit (YRT) System

The proposed development is adjacent to YRT Bus Route 56 Gorham Eagle stop and about 200 m from the Viva Blue stop on the Yonge Street and Eagle Street intersection. In addition, the Rapidway on Yonge Street in Newmarket, from Sawmill Valley Drive/Savage Road to Davis Drive, was opened for service on January 5, 2020. The existing transit network in the area is illustrated in Figure 5

Figure 5 – Existing Transit Network in the Area

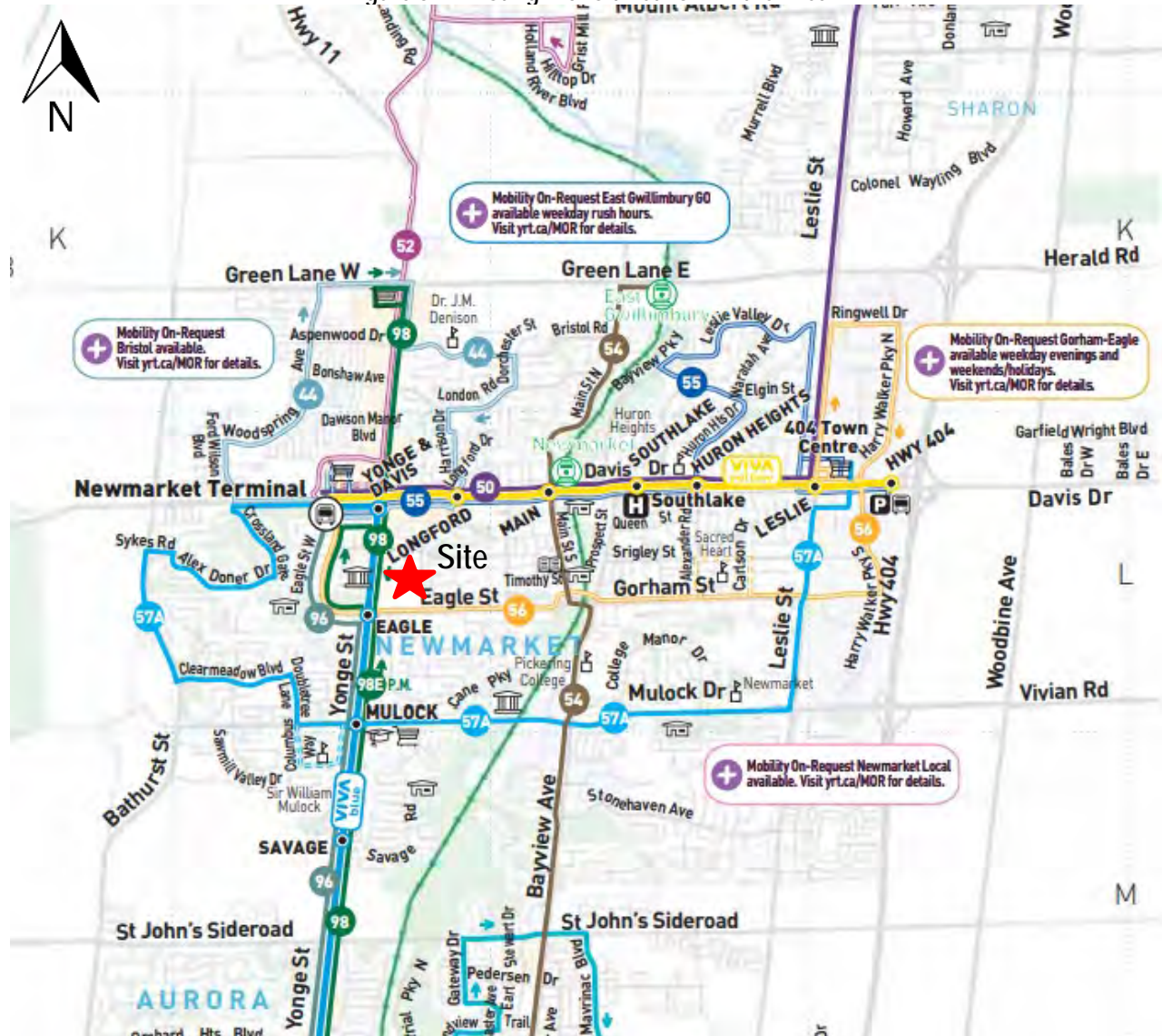

Sources: YRT Maps

Figure 6 – Yonge Transit Rapid Way



Source: Metrolinx – YRT/Viva Rapid way

YRT Bus Route descriptions:

- **YRT Bus Route 56 Gorham-Eagle** – The 589/590 Richmond Hill Local bus route operates generally in the east-west direction between Upper Canada Mall and 404 Town Centre. This route operates only on weekdays and the service frequency is about 1 hour during 9 AM to 6 PM.
- **Viva Blue** - The Viva Blue bus route is a bus rapid transit (BRT) that operates generally in the north-south direction between Finch GO Bus Terminal (Subway Connection) and Newmarket Terminal, and connects to Viva Yellow at Yonge/Davis stop. This Route operates all day and the service frequency is about 10-15 minutes during peak periods.

2.3. Existing Traffic Volumes

Existing traffic volumes at the study area intersections were from the following sources:

- Yonge Street and Eagle Street: undertaken by York Region on Wednesday January 19, 2020 during the morning (7:00 a.m. to 9:00 a.m.) and afternoon (3:00 p.m. to 6:00 p.m.) peak periods for signalized intersections.
- Dixon Boulevard and Eagle Street: undertaken by GENIVIAR on Thursday May 27, 2010 during the morning (6:30 a.m. to 9:30 a.m.) and afternoon (3:00 p.m. to 6:00 p.m.) peak periods for unsignalized intersections.
- Donlin Avenue and Eagle Street: undertaken by GENIVIAR on Thursday May 27, 2010 during the morning (6:30 a.m. to 9:30 a.m.) and afternoon (3:00 p.m. to 6:00 p.m.) peak periods for unsignalized intersections.
- Sanford Street/ Carol Avenue and Eagle Street: undertaken by Town of Newmarket on Wednesday October 14, 2009 during the morning (7:00 a.m. to 9:00 a.m.) and afternoon (3:00 p.m. to 6:00 p.m.) peak periods for signalized intersections.

In light of the COVID-19 pandemic, there are expectations and speculations that the traffic counts could not be undertaken due to office staff working from home. Students are also attending school online instead of travelling to the schools. For these reasons, it is expected that there will be less cars on the road during the peak period when the traffic counts are completed.

In order to understand the magnitude of the impact, NexTrans has prorated the outdated count by applying 0.5% to all movement of local roads (Dixon Boulevard, Donlin Avenue, Carol Ave/ Sanford Street), and balance with the existing count of Yonge St/ Eagle Street from York Region.

Turning movement counts are summarized in **Appendix A**. The existing prorated volumes are illustrated in **Figure 7**.

Figure 7 – Existing Balanced Traffic Volumes

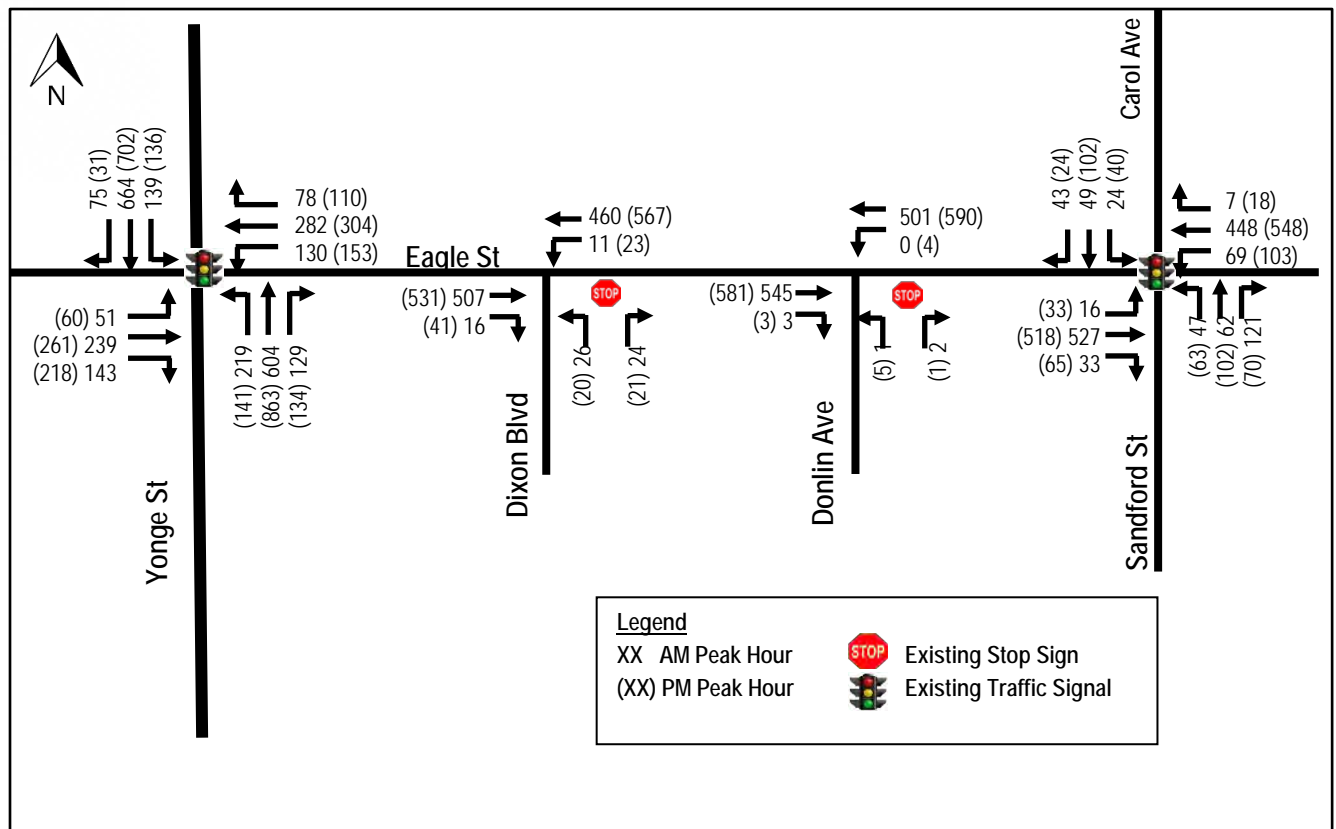

2.4. Existing Traffic Assessment

The existing volumes in **Figure 7** were analyzed using Synchro Version 9 software. The methodology of the software follows the procedures described and outlined in the Highway Capacity Manual, HCM 2000, published by the Transportation Research Board. The detailed results are provided in **Appendix B** and summarized in **Table 1**.

Table 1 – Existing Levels of Service for Signalized Intersections

Intersection	Key Movement	Weekday AM Peak Hour			Weekday PM Peak Hour		
		LOS (v/c)	Delay (s)	Queue 95 th (m)	LOS (v/c)	Delay (s)	Queue 95 th (m)
Yonge Street and Eagle Street (signalized)	Overall	D (0.68)	37.3		D (0.72)	37.8	
	EB – L	D (0.27)	40.2	23.1	D (0.29)	40.9	27.5
	EB – T	D (0.63)	43.6	83.6	D (0.64)	44.6	95.2
	EB - R	D (0.09)	38.4	16.2	D (0.17)	39.3	22.4
	WB – L	C (0.45)	27.6	37.5	C (0.61)	33.6	48.2
	WB – T	C (0.44)	28.2	79.2	C (0.49)	31.1	95.1
	WB - R	C (0.05)	23.8	8.8	C (0.07)	26.1	12.6
	NB – L	D (0.68)	48.4	85.2	D (0.58)	50.6	63.1
	NB – TR	C (0.67)	34.5	122.0	D (0.83)	39.8	171.7
	SB – L	D (0.53)	45.8	55.6	D (0.56)	50.4	61.2
SB – TR	D (0.75)	39.4	125.1	C (0.61)	32.5	116.7	
Eagle Street and Dixon Blvd (unsignalized)	WB – TL	A (0.01)	0.4	0.3	A (0.03)	0.7	0.6
	NB - LR	C (0.17)	18.8	4.6	C (0.19)	23.9	5.3
Eagle Street and Donlin Ave (unsignalized)	NB - LR	C (0.01)	15.4	0.2	B (0.11)	13.5	2.9
Sanford Street/ Carol Ave and Eagle Street (signalized)	Overall	A (0.41)	8.1		A (0.52)	10.6	
	EB – L	A (0.03)	2.6	2.6	A (0.09)	5.7	5.5
	EB – T	A (0.48)	50.0	50.0	A (0.52)	7.9	60.0
	EB - R	A (0.02)	2.1	2.1	A (0.04)	5.5	4.4
	WB – L	A (0.17)	8.2	8.2	A (0.26)	6.6	14.4
	WB – TR	A (0.42)	40.9	40.9	A (0.57)	8.5	67.9
	NB – L	B (0.15)	10.5	10.5	B (0.26)	18.9	14.9
	NB – TR	B (0.23)	17.6	17.6	B (0.39)	19.6	26.9
	SB – L	B (0.10)	6.6	6.6	B (0.17)	18.3	10.5
	SB – TR	B (0.14)	12.7	12.7	B (0.32)	19.1	23.1

The intersection operation capacity analysis indicates that all the intersections considered are currently operating at acceptable overall levels of service for urban conditions. No improvement is required at this time.

3.0 TRANSPORTATION PLANNING CONTEXT IN THE AREA

3.1. Land Use Context

Based on Nextrans comprehensive review of the study area, there is a wide range of land uses within 2 to 10 minutes walking distance of the subject site, including:

- High-rise residential condominium and apartment buildings;
- Medical centre/office and pharmacy;
- Financial institutions;
- Retail/commercial along Yonge Street;

- Institutions (elementary schools and churches); and
- Restaurants and fast-food establishment

3.2. Transportation Planning Context

As previously indicated, the proposed development is adjacent to YRT 56 Gorham Eagle bus stop and about 200 m from the Viva Blue bus stop on the Yonge Street and Eagle Street intersection. In addition, the reworking of Yonge Street in Newmarket for the Rapidway, from Sawmill Valley Drive/Savage Road to Davis Drive, was opened for service on January 5, 2020. This created dedicated bus rapid transit lanes, dedicated bicycle lanes and an important pedestrian environment with landscape boulevard and wider sidewalks.

Given this significant transit and streetscape investment, the proposed development represents good transportation and land use planning as the subject site's proximity to a rapid transit stop and improved walking environment encourages the future residents to walk, cycle and take public transit as an alternative to driving.

4.0 FUTURE BACKGROUND CONDITIONS

4.1. Analysis Horizon

For the purposes of this assessment, it is assumed that the proposed development will be fully built-out by 2023. As such, a five-year horizon (2028) after the entire building process of the proposed development has been carried out for the study analysis.

4.2. Future Background Corridor Growth

A comparison of the historical traffic volumes between 2012-2018 for Yonge Street and Eagle Street indicates the growth rate of 2% per annum for both Yonge Street and Eagle Street. As such, the growth rate of 2% per annum for Eagle Street and Yonge St, growth rate of 0.5% per annum for Dixon Blvd, Donlin Ave and Sanford St/ Carol Ave was used to prorated the turning movement count data for two signalized intersections as well as future background corridor growth. The historical traffic count regression analysis is included in **Appendix C**.

4.3. Background Development Applications

A full review of active developments within the study area was conducted based on the Town of Newmarket website portal, no background development will be considered in this study.

4.4. Future Background Traffic Assessment

The estimated 2028 future background traffic volumes are illustrated in **Figure 8** and were analyzed using Synchro Version 9 software. The detailed calculations are provided in **Appendix E** and summarized in **Table 3**.

Figure 8 – 2028 Future Background Traffic Volume

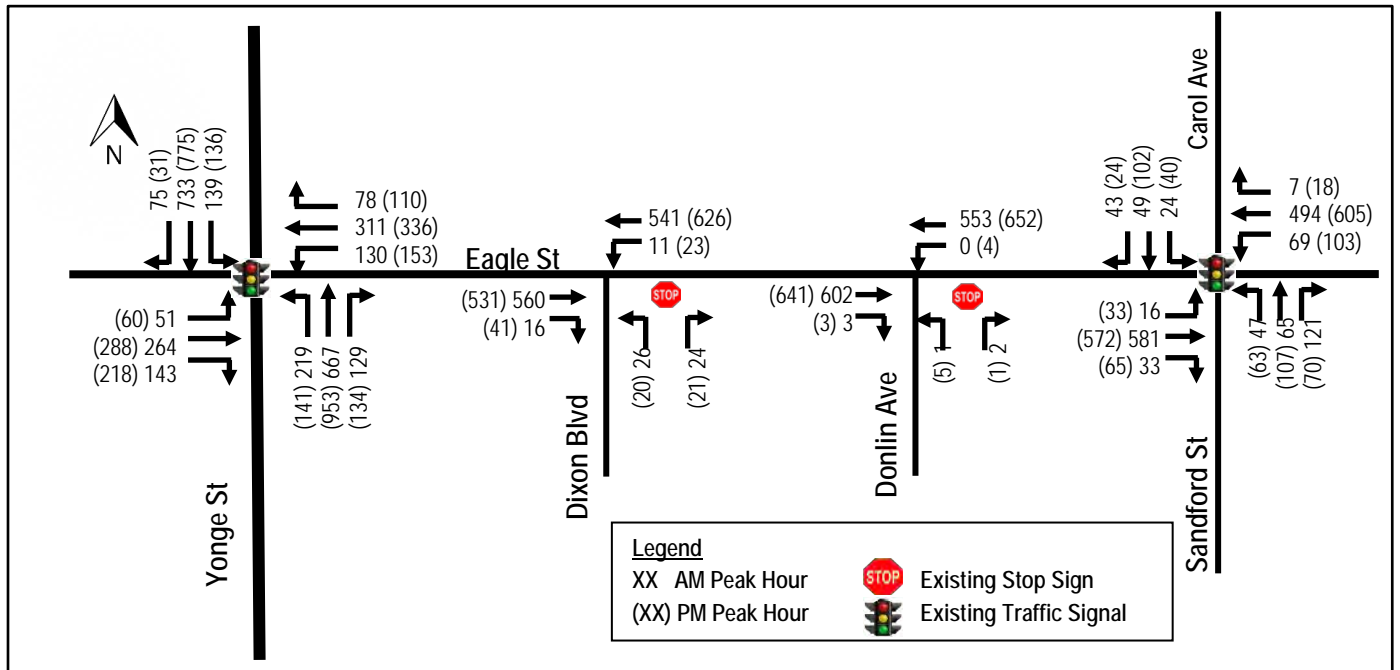

Table 3 – 2028 Future Background Levels of Service

Intersection	Key Movement	Weekday AM Peak Hour			Weekday PM Peak Hour		
		LOS (v/c)	Delay (s)	Queue 95 th (m)	LOS (v/c)	Delay (s)	Queue 95 th (m)
Yonge Street and Eagle Street (signalized)	Overall	D (0.69)	37.5		D (0.77)	40.6	
	EB - L	D (0.23)	37.1	22.4	D (0.29)	42.0	27.6
	EB - T	D (0.66)	44.3	92.0	D (0.68)	47.7	105.4
	EB - R	D (0.09)	35.6	15.5	D (0.21)	40.9	28.1
	WB - L	C (0.39)	25.8	36.2	D (0.67)	38.0	48.0
	WB - T	C (0.45)	27.0	85.0	C (0.54)	33.4	106.1
	WB - R	C (0.05)	22.4	8.4	C (0.08)	27.3	13.7
	NB - L	D (0.69)	50.1	86.8	D (0.60)	54.2	63.3
	NB - TR	C (0.70)	35.0	136.3	D (0.88)	44.1	208.3
Eagle Street and Dixon Blvd (unsignalized)	SB - L	D (0.53)	47.2	56.6	D (0.58)	53.7	61.4
	SB - TR	D (0.78)	40.4	142.5	C (0.65)	33.9	132.3
Eagle Street and Donlin Ave (unsignalized)	WB - TL	A (0.01)	0.3	0.3	A (0.03)	0.7	0.6
	NB - LR	C (0.21)	22.6	5.9	C (0.19)	24.1	5.3
Eagle Street and Donlin Ave (unsignalized)	NB - LR	C (0.01)	17.1	0.2	B (0.12)	14.3	3.2
Sanford Street/ Carol Ave and Eagle Street (signalized)	Overall	A (0.44)	8.2		A (0.52)	11.0	
	EB - L	A (0.04)	4.1	2.6	A (0.09)	5.7	5.7
	EB - T	A (0.53)	6.3	57.3	A (0.52)	7.9	70.3
	EB - R	A (0.02)	4.0	2.0	A (0.04)	5.5	4.6
	WB - L	A (0.19)	4.7	8.4	A (0.26)	6.6	15.5
	WB - TR	A (0.45)	5.8	46.3	A (0.57)	8.5	80.0
	NB - L	B (0.15)	16.0	11.1	B (0.26)	18.9	14.9
	NB - TR	B (0.24)	16.4	19.1	B (0.39)	19.6	28.0
	SB - L	B (0.10)	15.7	7.0	B (0.17)	18.3	10.5
SB - TR	B (0.14)	15.9	13.5	B (0.32)	19.0	23.1	

Under the future background conditions, the intersection operation capacity analysis indicates that all intersections considered are expected to operate at acceptable levels of service. No improvement is required at this horizon year.

5.0 SITE TRAFFIC

5.1. Proposed Development

As indicated, the development proposal consists of 53 townhouse units, 20 back-to-back townhouse units and 1 triplex house (3 units), in total of 76 dwelling units.

The 2016 Transportation Tomorrow Survey (TTS) and the *Trip Generation Manual, 10th Edition* published by the Institute of Transportation Engineers (ITE) information was reviewed to estimate the modal split, trip distribution and trip generation for the proposed development.

5.2. Modes of Travel Assessment in the Area

Table 4 summarizes the travel mode split information, based on the review of the 2016 Transportation Tomorrow Survey data, for traffic zones 2612,2613,2614,2615. The detailed analysis and TTS data extraction are included in Appendix F.

Table 4 – Modes of Travel based on 2016 TTS Data for Traffic Zones 2612,2613,2614,2615

Time	Trips Made by Traffic Zones 2612,2613,2614,2615					
	Auto Driver	Auto Passenger	Taxi/Paid Ride Share	Transit	Cycle	Walk
AM Peak Period (6:00-9:00 AM)	74%	8%	0%	8%	0%	10%
PM Peak Period (3:00-6:00 PM)	82%	14%	0%	1%	0%	3%

Based on the information outlines in the table above, the predominant modes of travel to and from the area are auto driver mode with 74% during the morning and 82% during the afternoon peak periods, respectively.

5.3. Site Trip Generation

For the purposes of this assessment, the *Trip Generation Manual, 10th Edition* published by the Institute of Transportation Engineers (ITE) was reviewed to estimate the site generated trips. Based on our review, the selected corresponding land use code is “Multifamily Housing Low-Rise” Land Use Code (LUC) 220 General Urban-suburban. Table 5 summarizes the site trip generation estimate for the current development proposal based on the ITE trip rates using fitted curve equations, where appropriate.

Table 5 – Site Total Trip Generation for Current Development Proposal

LUC	Magnitude (unit)	Parameter	Modal Split		Morning Peak			Afternoon Peak		
			AM	PM	IN	OUT	TOTAL	IN	OUT	TOTAL
Multifamily Housing (Low-rise) (LUC 220) General Urban - Suburban	76	Total trips	100%	100%	8	28	36	29	17	46
		Transit Trips	8%	1%	1	2	3	0	0	0
		Walking Trips	10%	3%	1	3	4	1	0	1
		Cycling Trips	0%	0%	0	0	0	0	0	0
		Auto Passenger	8%	14%	1	2	3	4	2	6
		Auto Trips	74%	82%	6	21	27	24	14	38

The proposed development is expected to generate:

- 36 total new two-way trips (8 inbound and 28 outbound) during the weekday morning and 46 total new two-way trips (29 inbound and 17 outbound) during the afternoon peak hours, respectively;
- 3 total new two-way transit trips (1 inbound and 2 outbound) during the weekday morning and 0 total new two-way transit trips (0 inbound and 0 outbound) during the afternoon peak hours, respectively;
- 27 total new two-way auto trips (6 inbound and 21 outbound) during the weekday morning and 38 total new two-way auto trips (24 inbound and 14 outbound) during the afternoon peak hours, respectively;
- 4 total new two-way active trips (1 inbound and 4 outbound) during the weekday morning and 1 total new two-way auto trips (1 inbound and 0 outbound) during the afternoon peak hours, respectively.

5.4. Site Trip Distribution and Assignment

The 2016 Transportation Tomorrow Survey (TTS) data was reviewed for traffic zones 2612,2613,2614,2615 in order to estimate the general trip distribution for the proposed development. **Table 6** summarizes the planning district/traffic zones distribution based on the 2016 TTS data.

Table 6 – Trip Distribution for Residential Component

Mode	Toronto	York Region	Durham Region	Peel Region	Simcoe County	Total
Auto	11%	75%	9%	1%	4%	100%

Table 7 summarizes the site trip assignment based on the 2016 TTS and existing transportation network in the area for the residential component of proposed development.

Table 7 – Site Trip Distribution

General Direction of Travel (To/From)	Auto
North	16%
South	33%
East	28%
West	23%
Total	100%

Figure 9 illustrates the proposed development generated traffic volumes. It should be noted that the auto site trip distribution and assignment have been taken into consideration the TTS information, existing turning restrictions, as well as existing intersection operations and capacity constraints.

Figure 9 – Site Trip Assignment

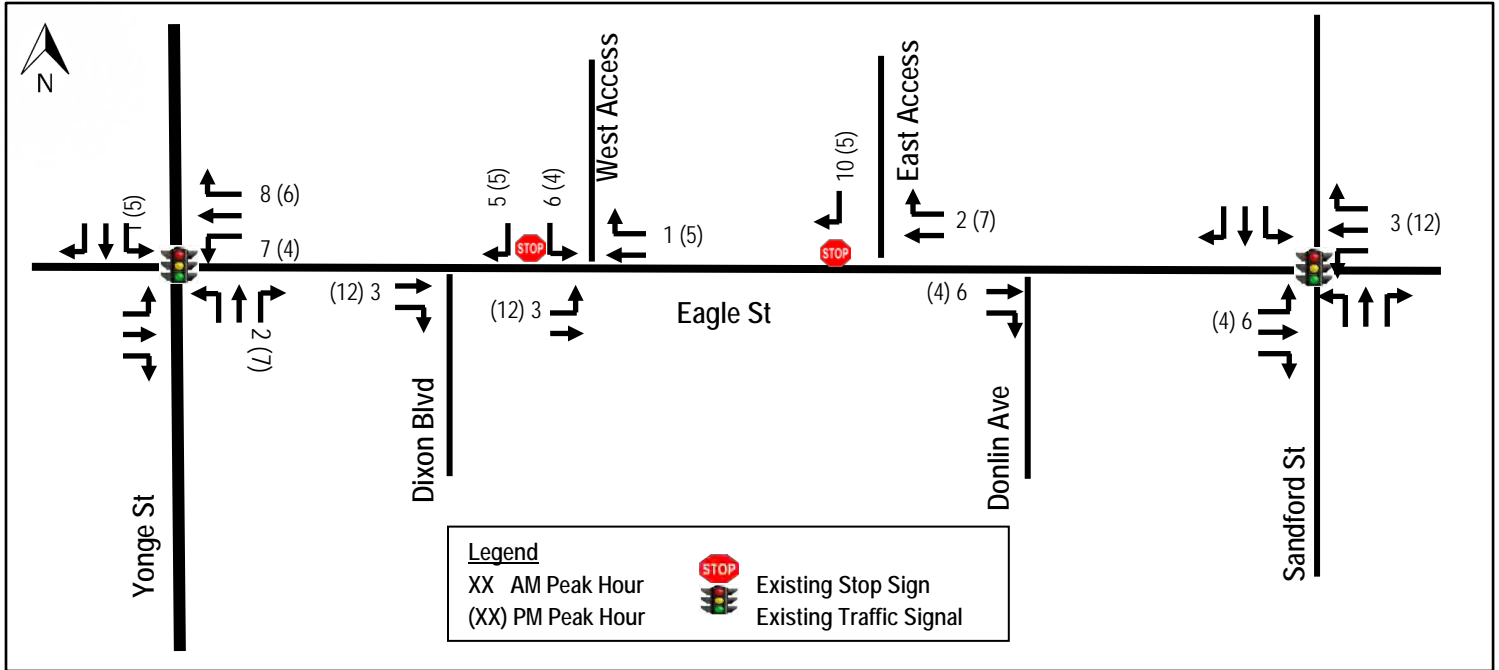

6.0 FUTURE TOTAL TRAFFIC CONDITIONS

6.1 Future Total Traffic Assessment for Auto Mode

The estimated future total traffic volumes (future background traffic volumes plus site generated traffic volumes) are illustrated in Figure 10, and were analyzed using Synchro Version 9 software. The detailed calculations are provided in Appendix G and summarized in Table 8.

Figure 10 – 2028 Future Total Traffic Volume

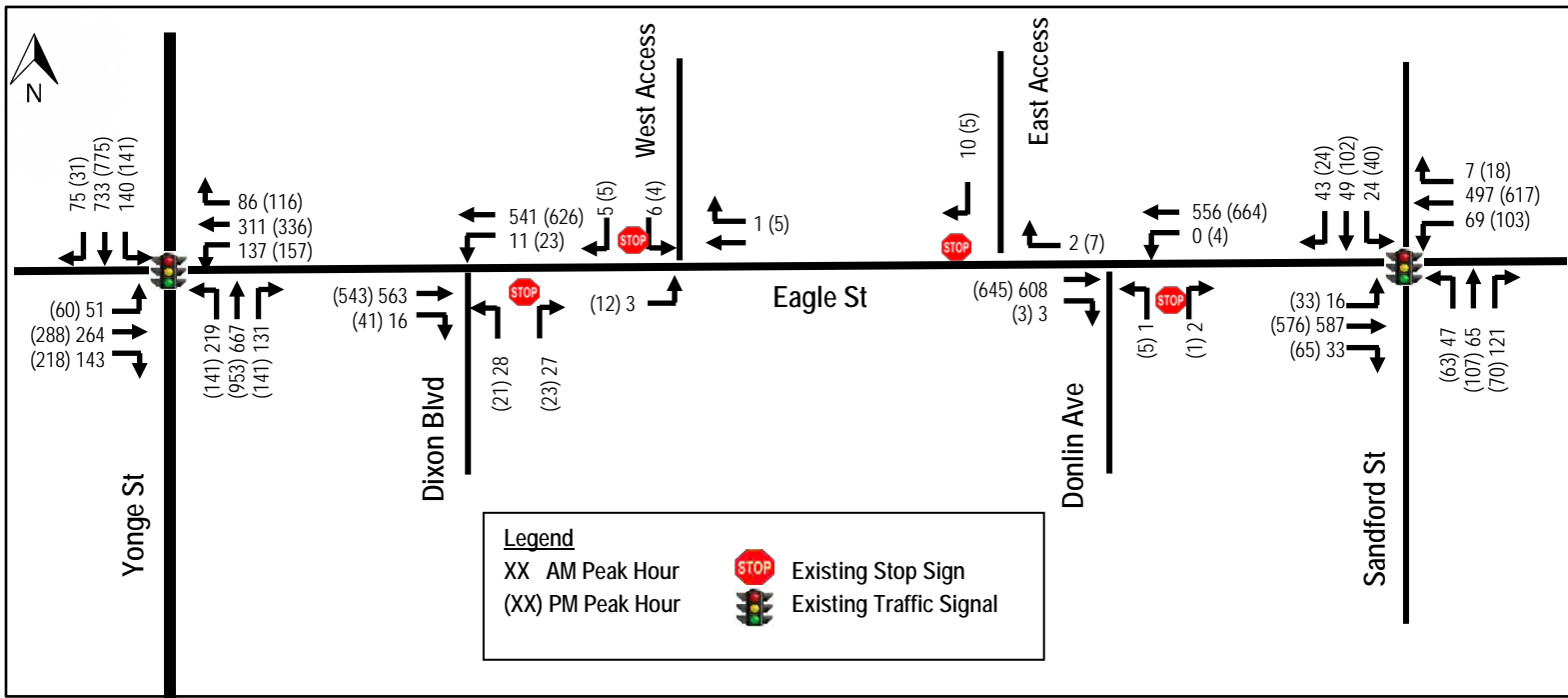

Table 8 – 2028 Future Total Levels of Service

Intersection	Key Movement	Weekday AM Peak Hour			Weekday PM Peak Hour		
		LOS (v/c)	Delay (s)	Queue 95 th (m)	LOS (v/c)	Delay (s)	Queue 95 th (m)
Yonge Street and Eagle Street (signalized)	Overall	D (0.69)	37.6		D (0.77)	40.6	
	EB – L	D (0.26)	37.2	22.4	D (0.29)	42.0	27.6
	EB – T	D (0.66)	44.4	92.0	D (0.68)	47.7	105.4
	EB - R	D (0.09)	35.7	15.5	D (0.21)	40.9	28.1
	WB – L	C (0.48)	26.0	38.1	D (0.67)	38.0	48.0
	WB – T	C (0.47)	27.0	85.0	C (0.54)	33.4	106.1
	WB - R	C (0.05)	22.4	9.9	C (0.08)	27.3	13.7
	NB – L	D (0.70)	50.2	86.8	D (0.60)	54.2	63.3
	NB – TR	D (0.74)	35.3	136.6	D (0.88)	44.1	208.3
	SB – L	D (0.54)	47.3	56.8	C (0.58)	53.7	61.4
SB – TR	D (0.83)	40.5	142.5	C (0.65)	33.9	132.3	
Eagle Street and Dixon Blvd (unsignalized)	WB – TL	A (0.01)	0.3	0.3	A (0.03)	0.7	0.6
	NB - LR	C (0.21)	22.6	5.9	C (0.19)	24.1	5.3
Eagle Street and Donlin Ave (unsignalized)	NB - LR	C (0.01)	17.3	0.2	B (0.12)	14.3	3.2
Sanford Street/ Carol Ave and Eagle Street (signalized)	Overall	A (0.44)	8.2		A (0.52)	11.0	
	EB – L	A (0.04)	4.1	2.6	A (0.09)	5.7	5.7
	EB – T	A (0.53)	6.3	57.3	A (0.52)	7.9	70.3
	EB - R	A (0.02)	4.0	2.0	A (0.04)	5.5	4.6
	WB – L	A (0.19)	4.7	8.4	A (0.26)	6.6	15.5
	WB – TR	A (0.46)	5.8	46.3	A (0.57)	8.5	80.0
	NB – L	B (0.15)	16.0	11.1	B (0.26)	18.9	14.9
	NB – TR	B (0.24)	16.4	19.1	B (0.39)	19.6	28.0
	SB – L	B (0.10)	15.7	7.0	B (0.17)	18.3	10.5
SB – TR	B (0.14)	15.9	13.5	B (0.32)	19.0	23.1	
Eagle Street and Proposed Access West (unsignalized)	EB – LT	A (0.00)	0.1	0.1	A (0.01)	0.1	0.3
	SB - LR	C (0.04)	18.6	1.0	C (0.04)	21.6	0.9
Eagle Street and Proposed Access East (unsignalized)	SB - LR	B (0.02)	12.1	0.5	C (0.01)	12.2	0.2

Based on the intersection capacity analysis, under the future total conditions, all the intersections considered are expected to operate at acceptable overall levels of service for urban conditions. No improvement is required at this horizon year. It should be noted that the proposed development contributes negligible delay or queues to the existing intersections and transportation work in the area.

The analysis indicates that the proposed accesses via Eagle Street are expected to operate at acceptable levels of service with minimal delays or queues. No improvement to the existing or planned street system would be required to accommodate the proposed development.

6.2. Pedestrian Mode Assessment

Table 9 summarizes the pedestrian performance at Yonge Street/Eagle Street intersection and both side of Eagle Street, in the vicinity of the proposed development.

Table 9 – Pedestrian Level of Service Summary

Location	Direction	Level of service	
		Segment	Intersection
Yonge Street and Eagle Street	Eastbound	B	B
	Westbound	B	B
	Northbound	B	A
	Southbound	B	A
Both side of Eagle Street	Eastbound	B	B
	Westbound	B	B

As indicated in **Table 9**, the pedestrian performance in the vicinity is expected at acceptable levels of service, no improvement is required to accommodate the proposed development.

6.3. Transit Mode Assessment

As indicated, the proposed development is expected to generate 3 total new two-way transit trips (1 inbound and 2 outbound) during the weekday morning and 0 total new two-way transit trips (0 inbound and 0 outbound) during the afternoon peak hours, respectively.

The transit passenger demands generated by the proposed development per transit vehicle is very low (at most 2 passenger per transit vehicle per hour). As such, the proposed development impact on transit service is negligible and no improvements are required.

In practice, passengers may be bunched together during the peak 15 minutes, instead of spreading during the entire peak hour. Nonetheless, our estimates indicate that the demand per vehicle is extremely low and can be accommodated without the need for additional transit vehicles or improvements during both the morning and afternoon peak periods.

Table 10 summarizes the transit level of service for transit stop locations at Yonge Street/ Eagle Street intersection.

Table 10 – Transit Level of Service Summary

Transit Stop Location	Direction	Access to Transit Stops	Transit Headways	Intersection Approach
		LOS	LOS	LOS
Yonge Street/ Eagle Street	Northbound	A	C	A
	Southbound	A	C	A

As indicated in **Table 10**, the transit stop locations in the vicinity are expected at acceptable levels of service during the morning and afternoon peak hours.

7.0 SITE PLAN REVIEW

As indicated, the redevelopment proposal consists of 53 townhouse units, 20 back-to-back townhouse unit and one triplex house (3 units), in total of 76 units. The garbage will be picked up on the curb side of private road.

The AutoTurn analysis was undertaken using a typical 12.0 – meter Garbage Truck, and fire truck, as illustrated in **Figure 11**. The analysis demonstrates that a typical garbage truck and fire truck can maneuver within the designed route, internal roadway and site accesses via Eagle Street with no conflict. Additionally, a moving truck under 12.0 meter can sufficiently access the subject site.

8.0 PARKING ASSESSMENT

8.1. Vehicle Parking Requirement

The Town of Newmarket Zoning By-law 2010-40 Consolidated November 2018 is applied to the proposed development. The parking requirement and supply for the proposed development is summarized in Table 11.

Table 11 – Town of Newmarket Zoning By-law 2010-40 Vehicle Parking Requirements

Type	No. of Unit	Parking Rates	Parking Requirement	Parking Provide	Diff.
Townhouse or Stacked Townhouse Dwelling on Private Road	76 units	1.5 parking spaces/ unit	114	91	-23
Visitor Parking	76 units	0.25 parking spaces/ unit	19	35	+16
Total	76 units		133	126	-7

Based on the Town of Newmarket Zoning By-law 2010-40, the proposed development requires in total of 133 parking spaces (including 114 spaces for resident and 19 spaces for visitor). It is our understand that the proposed development provides in total of 126 parking spaces (including 91 spaces for resident and 35 spaces for visitor) through driveways for each townhome unit and shared site parking for the triplex and visitors, which present a technical shortfall of 23 parking spaces for residential, and surplus of 16 visitor parking.

NexTrans also reviewed the Town of Newmarket Urban Centres Zoning By-law 2019-06, in order to support the purpose of York Region Transportation Master Plan (2016), as well as York Region Transit’s (YRT/Viva) 2016-2020 Strategic Plan, as reducing single-auto trip to and from the proposed development and encourage residents to use public transit and other alternative transportation modes, and the subject site is located adjacent to the Zoning Area and Yonge Transit Rapidway amenity, as such, we recommend this Zoning By-law with lower parking rate for the proposed development.

The parking requirement and supply for the proposed development based on the suggestion is summarized in Table 12.

Table 12 – Town of Newmarket Urban Centres Zoning By-law 2019-06 Vehicle Parking Requirements

Type	No. of Unit	Parking Rates	Parking Requirement	Parking Provide	Diff.
Townhouse or Stacked Townhouse Dwelling on Private Road	76 units	1.0 parking spaces/ unit	76	91	+15
Visitor Parking	76 units	0.15 parking spaces/ unit	11	35	+24
Total	76 units		85	126	39

Based on the Zoning By-Law 2019-06, a total of 85 parking spaces are required for the proposed development. It is our understanding that the proposed development provides a total of 126 vehicle parking spaces (including 91 parking spaces for resident and 35 parking spaces for visitor) through driveways for each townhome unit and shared site parking for the triplex and visitors, which meets this By-law requirement.

9.0 TRANSPORTATION DEMAND MANAGEMENT

Transportation Demand Management (TDM) is a co-ordinated series of actions aimed at maximizing the people moving capability of the transportation system. It is intended help reduce single-occupant auto use. Potential TDM measures may include but not limited to: TDM supportive land use, bicycle and pedestrian programs and facilities, public transit

improvements, preferential treatments for buses and high occupancy vehicles (if applicable), ridesharing, and employee incentives.

Based on the review of the context of the proposed development in relation to the TDM requirements in the Region's Transportation Mobility Plan Guidelines for Development Applications, the following TDM measures and incentives are recommended for the proposed development:

Table 13 – Recommended TDM Measures for the Proposed Development

Category	TDM Measures or NexTrans Recommendations (York Region Transportation Mobility Plan Guidelines, Table 13, page 48)	Recommended Actions	Responsibility
Cycling and Walking	<ul style="list-style-type: none"> • Pedestrian Connections • Cycling Connections • Ped/cycling connections to transit facilities • Internal ped/cycling circulation • Active transportation network/fine-grid 	<ul style="list-style-type: none"> • The proposed development provides shared pedestrian connection (internal sidewalk) to Eagle Street, and provide a short and direct connection to VIVA Station at Yonge Street. 	<ul style="list-style-type: none"> • Applicant
Transit	<ul style="list-style-type: none"> • Information packages (YRT/VIVA maps, GO schedules, cycling maps) • Communication strategy and physical location to deliver PRESTO cards and information packages 	<ul style="list-style-type: none"> • The applicant shall coordinate with York Region to deliver and promote the Transit Incentive and New Resident Information Packages programs. 	<ul style="list-style-type: none"> • Applicant should discuss with York Region

10.0 CONCLUSIONS / FINDINGS

10.1. Study Conclusions

The findings and conclusions of the analysis are as follows:

- The proposed development is expected to generate:
 - 36 total new two-way trips (8 inbound and 28 outbound) during the weekday morning and 46 total new two-way trips (29 inbound and 17 outbound) during the afternoon peak hours, respectively;
 - 3 total new two-way transit trips (1 inbound and 2 outbound) during the weekday morning and 0 total new two-way transit trips (0 inbound and 0 outbound) during the afternoon peak hours, respectively;

- 27 total new two-way auto trips (6 inbound and 21 outbound) during the weekday morning and 38 total new two-way auto trips (24 inbound and 14 outbound) during the afternoon peak hours, respectively;
- 4 total new two-way active trips (1 inbound and 4 outbound) during the weekday morning and 1 total new two-way auto trips (1 inbound and 0 outbound) during the afternoon peak hours, respectively.
- Based on the intersection analysis, under the existing, future background and future total, all intersections are considered to be expected to operate at acceptable levels of service.
- The proposed development contributes negligible delay or queues to the existing intersections and transportation work in the area. The analysis indicates that the proposed accesses via Eagle Street are expected to operate at acceptable levels of service with minimal delays or queues.
- The analysis indicates that the transit passenger demands generated by the proposed development per transit vehicle is very low (less than one passenger per transit vehicle). As such, the proposed development impact on transit service is negligible and no improvements are required.
- Based on the Town of Newmarket Zoning By-law 2010-40, the proposed development requires in total of 133 parking spaces (including 114 spaces for resident and 19 spaces for visitor). It is our understanding that the proposed development provides in total of 126 parking spaces (including 91 spaces for resident and 35 spaces for visitor) through driveways for each townhome unit and shared site parking for the triplex and visitors, which present a technical shortfall of 23 parking spaces for residential, and surplus of 16 visitor parking.
- NexTrans also reviewed the Town of Newmarket Urban Centres Zoning By-law 2019-06, in order to support the purpose of York Region Transportation Master Plan (2016), as well as York Region Transit's (YRT/Viva) 2016-2020 Strategic Plan, as reducing single-auto trip to and from the proposed development and encourage residents to use public transit and other alternative transportation modes, and the subject site is located adjacent to the Zoning Area and Yonge Transit Rapidway amenity, as such, we recommend this Zoning By-law with lower parking rate for the proposed development.
- Based on the Zoning By-Law 2019-06, a total of 85 parking spaces are required for the proposed development. It is our understanding that the proposed development provides a total of 126 vehicle parking spaces (including 91 parking spaces for resident and 35 parking spaces for visitors) through driveways for each townhome unit and a shared site parking for the triplex and visitors, which meets this By-law requirement.
- The proposed accesses (one full movement and one RI-RO) via Eagle Street are expected to operate at acceptable levels of service with minimal delays or queues. No improvement to the Eagle Street is required to accommodate the proposed development.
- The proposed development will use private garbage pick up on the curb side of private road.
- The AutoTurn analysis demonstrates that a typical garbage truck and fire truck can maneuver within the designed route, internal roadway and site accesses via Eagle Street with no conflict. Additionally, a moving truck under 12.0 meter can sufficiently access the subject site.

10.2. Study Recommendations

Based on the Study assessment, our report recommends that:

- The proposed development implements the TDM measures and incentives in this report to support active transportation and transit and to reduce the numbers of single-occupant-vehicle trips to and from the proposed development;

- The proposed development provides direct shared pedestrian and cycling connections (internal sidewalk) from the proposed development to Eagle Street and Yonge Street where appropriate;
- No improvement to the existing or planned street would be required to accommodate the proposed development.

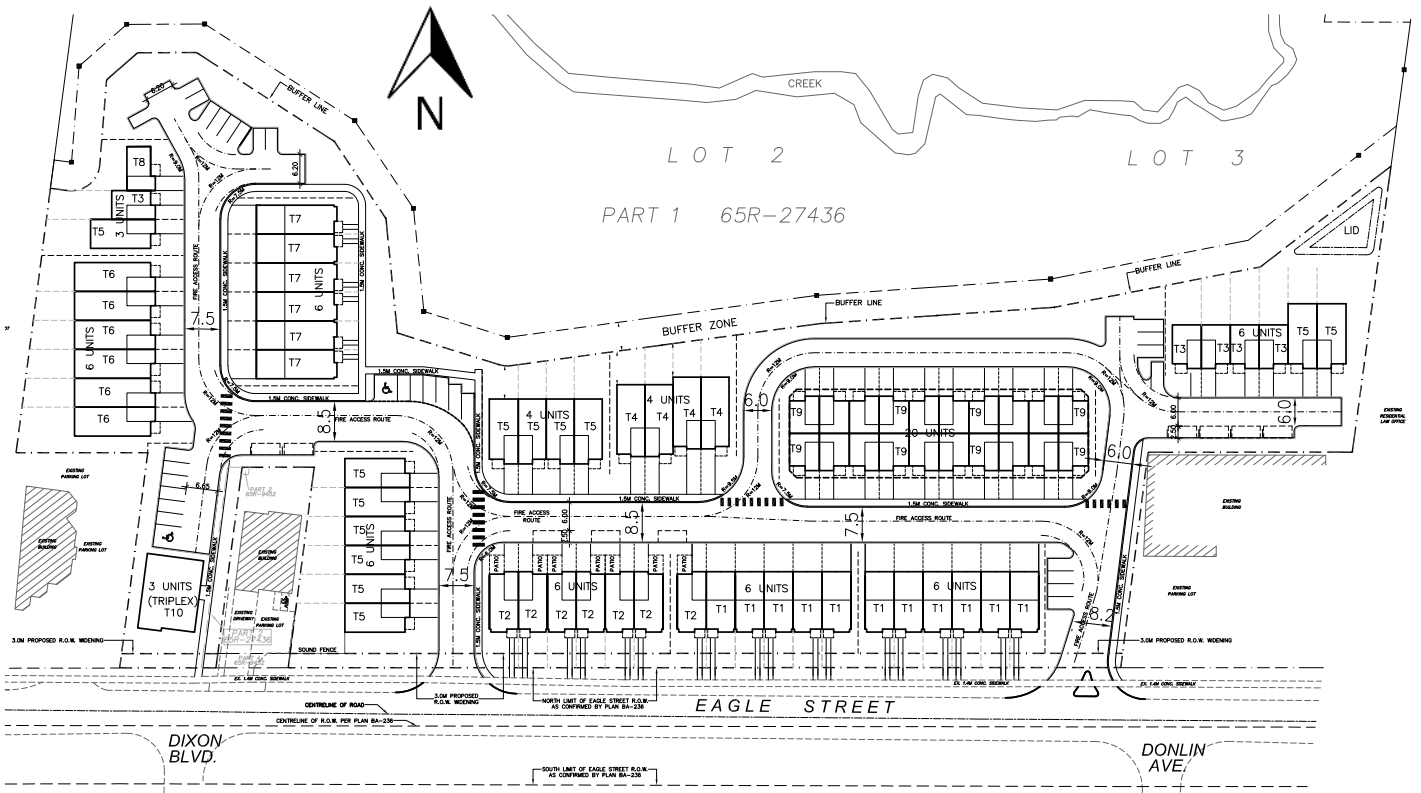

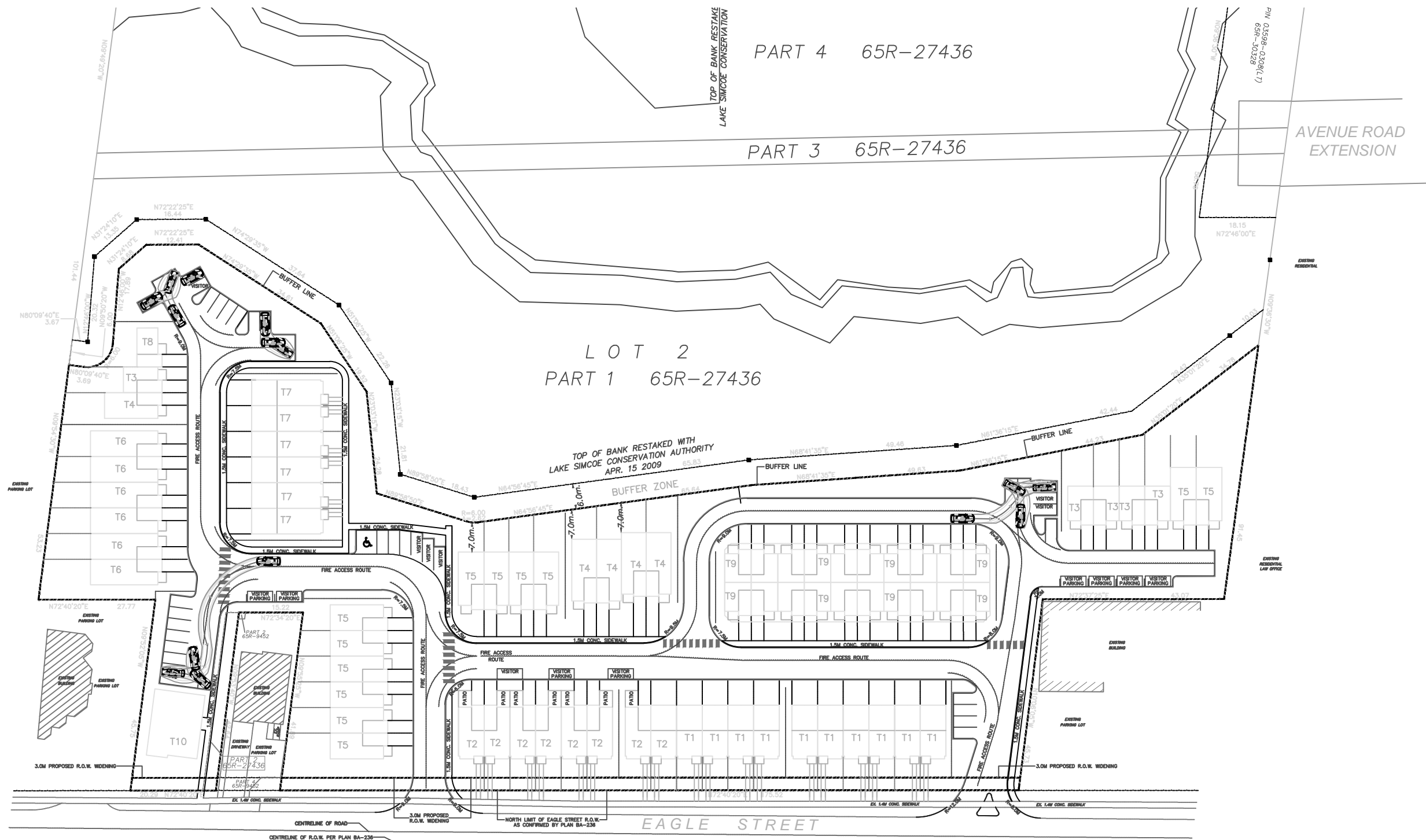

PART 4 65R-27436

PART 3 65R-27436

LOT 2
PART 1 65R-27436

AVENUE ROAD
EXTENSION

EAGLE STREET

DIXON
BLVD.

DONLIN
AVE

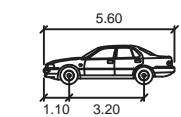

- P
- Width : 2.00
 - Track : 2.00
 - Lock to Lock Time : 6.0
 - Steering Angle : 35.9

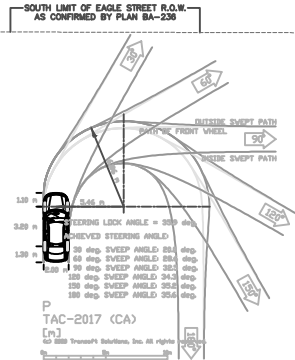

BENCHMARK

REVISIONS

NO	REVISION	DATE	BY

STAMP

nextrans
CONSULTING ENGINEERS
Suite 201, 520 Industrial Parkway South
Aurora ON L4G 6W8
Tel: 905-503-2563
Web: www.nextrans.ca

PROJECT NAME:
RESIDENTIAL DEVELOPMENT
55 Eagle Street
(TOWN OF NEWMARKET)

DRAWING TITLE:
AutoTURN Analysis
(P TAC-2017)

DESIGN BY: K.A.	DATE: February 10, 2021
CHECKED BY: R.P.	PROJECT NO.:
DRAWN BY: A.S.	NT-20-026
SCALE: NTS	DRAWING NO.:
	Figure 11

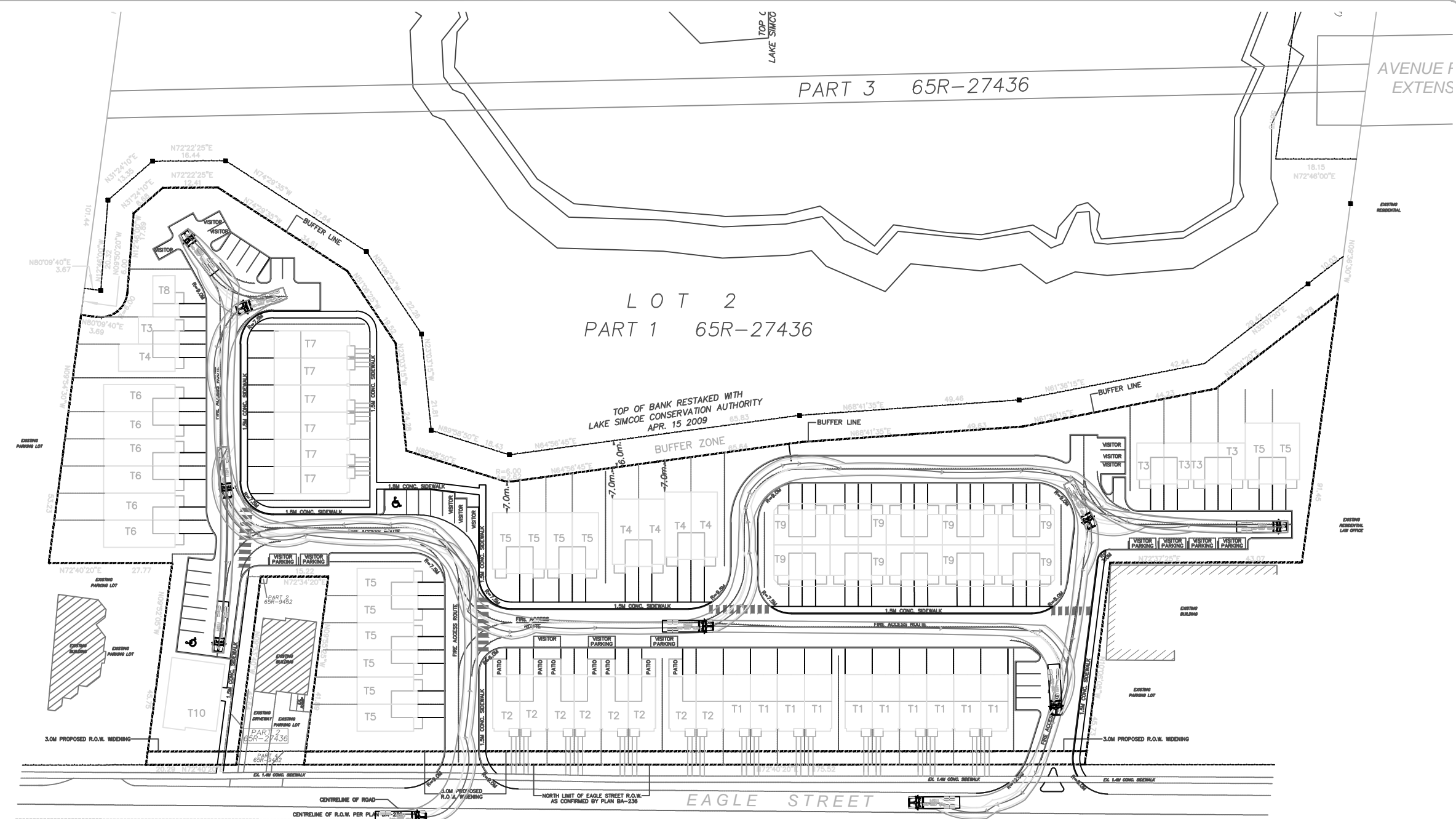

KEY PLAN



BENCHMARK

REVISIONS

NO	REVISION	DATE	BY

STAMP

nextrans
CONSULTING ENGINEERS
Suite 201, 520 Industrial Parkway South
Aurora ON L4G 6W8
Tel: 905-503-2563
Web: www.nextrans.ca

PROJECT NAME:
RESIDENTIAL DEVELOPMENT
55 Eagle Street
(TOWN OF NEWMARKET)

DRAWING TITLE:
AutoTURN Analysis
(HSU TAC-2017)

DESIGN BY: K.A.	DATE: February 10, 2021
CHECKED BY: R.P.	PROJECT NO.
DRAWN BY: K.A.	NT-20-026
SCALE: NTS	DRAWING NO. Figure 12

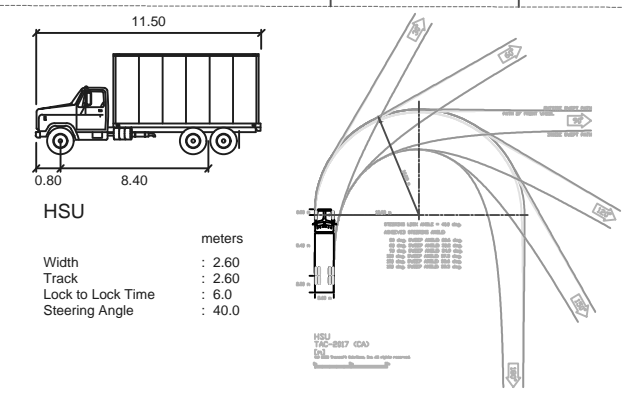

APPENDIX A

TRAFFIC DATA



Turning Movements Diagram Peak Hour Report: AM Period

Location..... Yonge Street & Eagle Street/Eagle Street West

GeoID..... E67DABC1

Municipality. Newmarket

Count Date. Wednesday, 19 February, 2020

Traffic Cont. Traffic signal

Count Period. 07:00 AM – 09:00 AM

Major Dir..... None

Peak Hour.... 08:00 AM – 09:00 AM

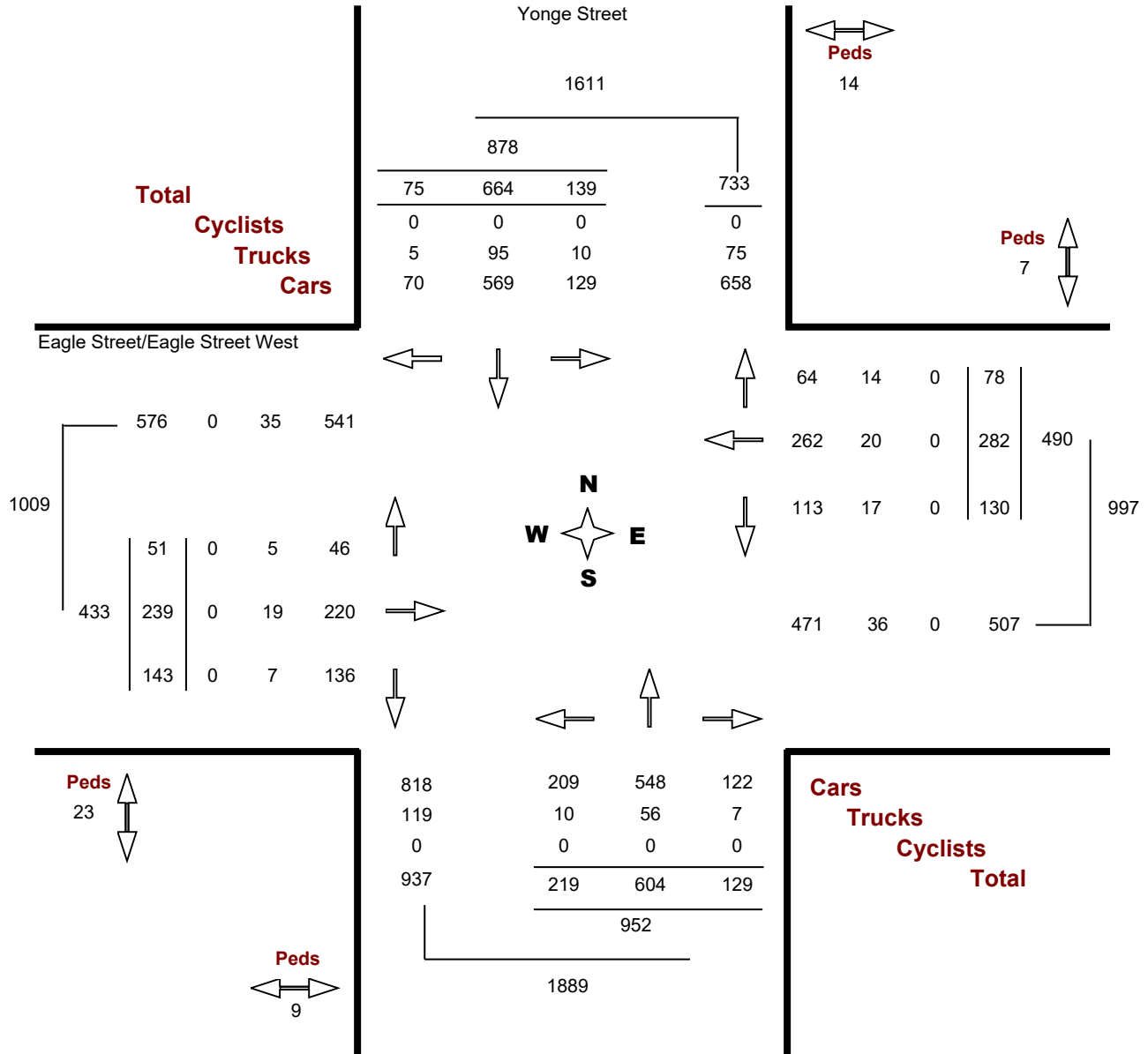

Notes:

Turning Movements Diagram Peak Hour Report: MD Period

Location..... Yonge Street & Eagle Street/Eagle Street West

GeoID..... E67DABC1

Municipality. Newmarket

Count Date. Wednesday, 19 February, 2020

Traffic Cont. Traffic signal

Count Period. 11:00 AM – 02:00 PM

Major Dir..... None

Peak Hour.... 12:00 PM – 01:00 PM

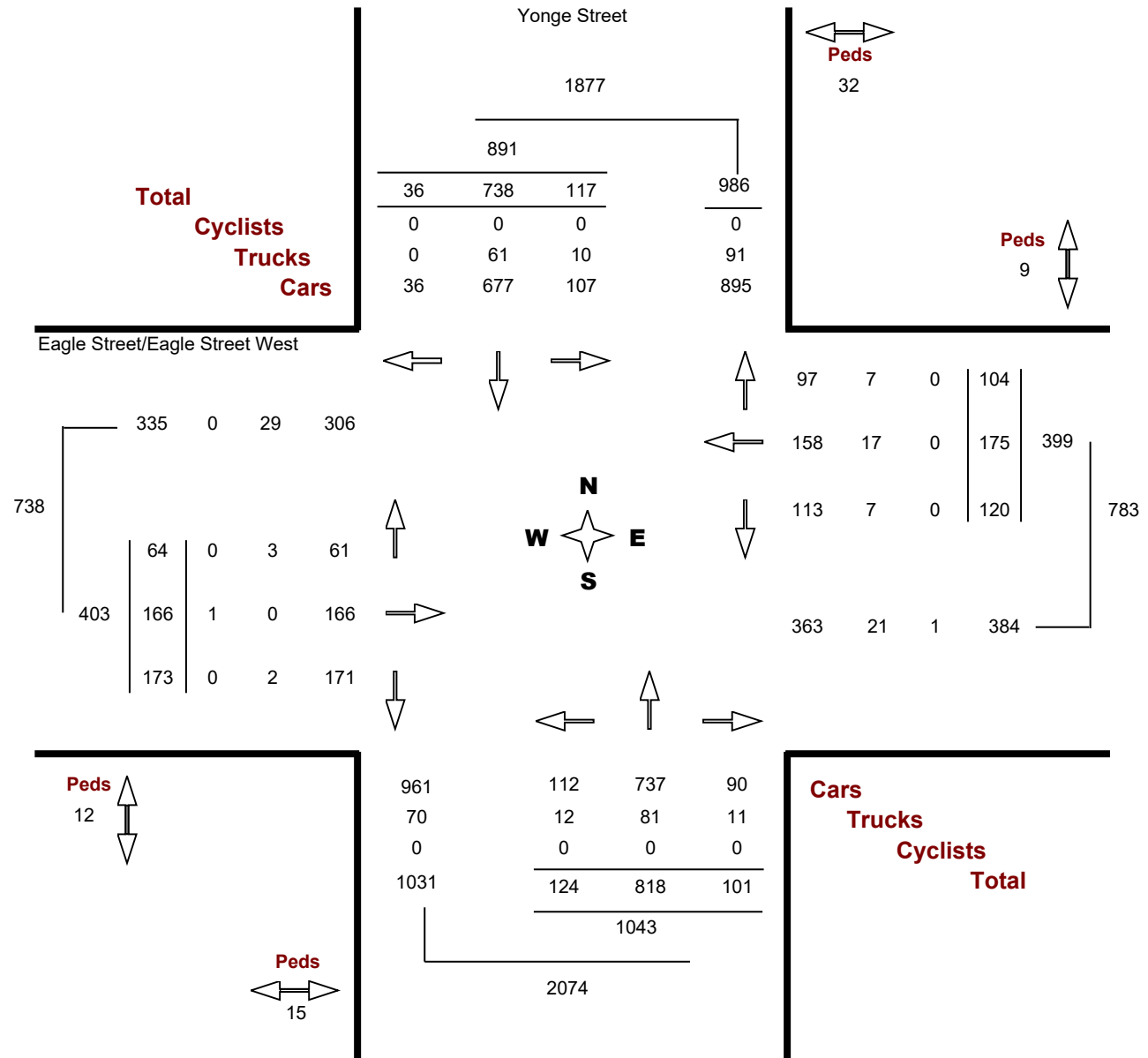

Notes:

Turning Movements Diagram Peak Hour Report: PM Period

Location..... Yonge Street & Eagle Street/Eagle Street West

GeoID..... E67DABC1

Municipality. Newmarket

Count Date. Wednesday, 19 February, 2020

Traffic Cont. Traffic signal

Count Period. 03:00 PM – 06:00 PM

Major Dir..... None

Peak Hour.... 04:30 PM – 05:30 PM

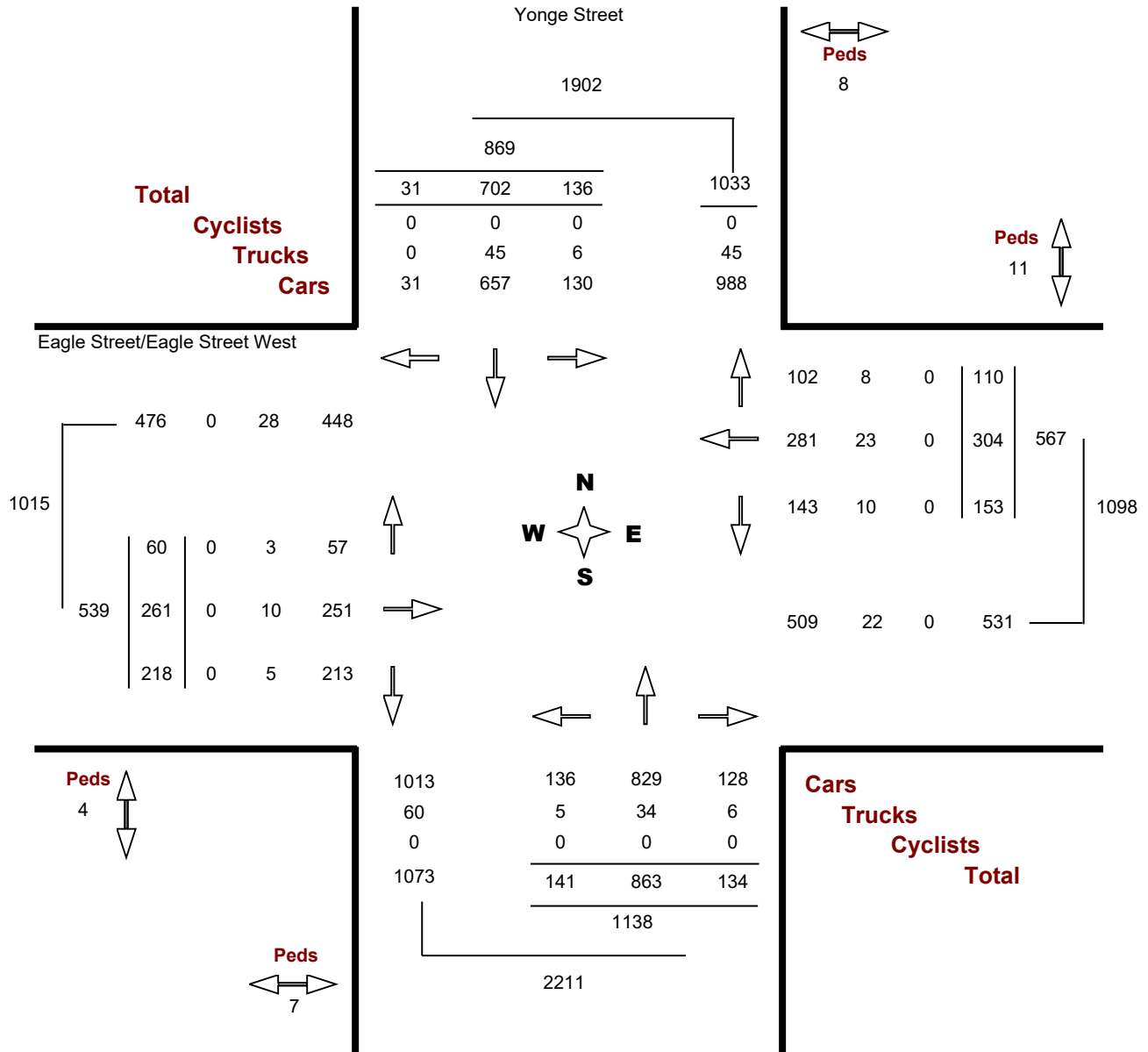

Notes:



Horizon Data Services Ltd.
318 Simonston Boulevard

Thornhill, Ontario, Canada L3T4T5
(416) 436-3166 irie.one@rogers.com

Count Name: Eagle St & Donlin Ave
Site Code:
Start Date: 05/27/2010
Page No: 5

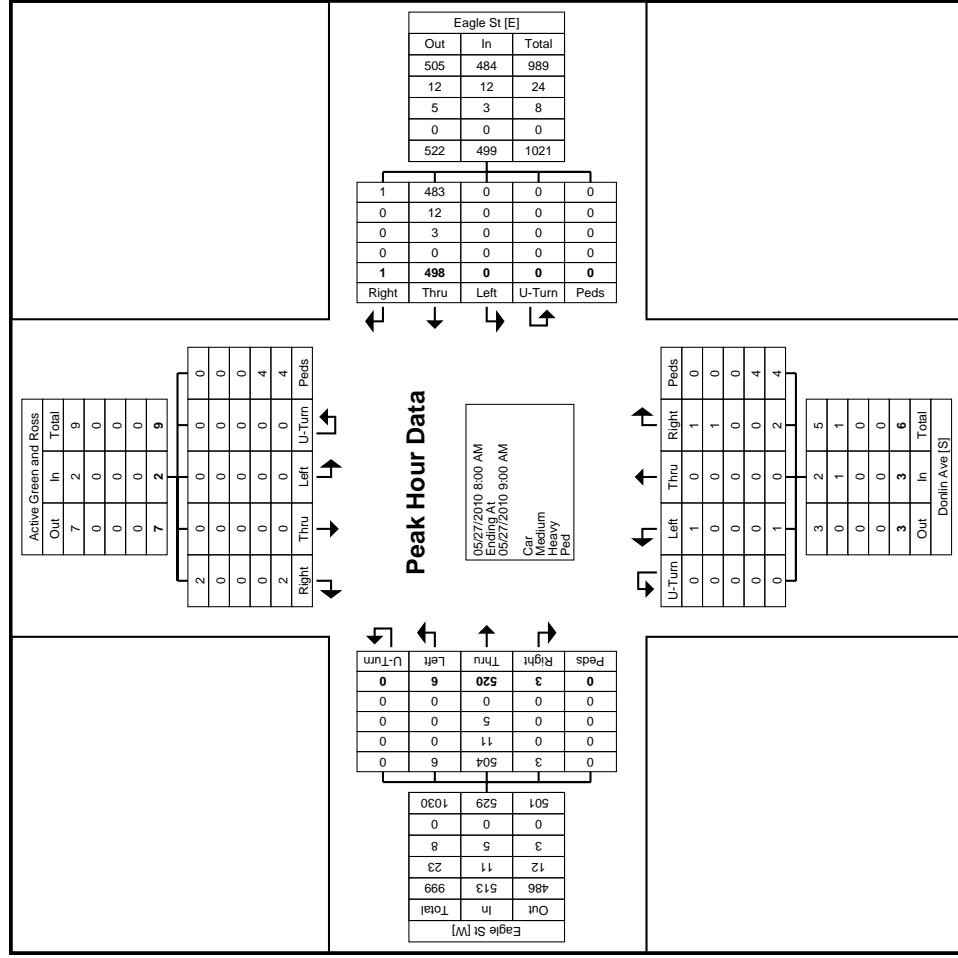

Turning Movement Peak Hour Data Plot (8:00 AM)



Horizon Data Services Ltd.
318 Simonston Boulevard

Thornhill, Ontario, Canada L3T4T5
(416) 436-3166 irie.one@rogers.com

Count Name: Eagle St & Donlin Ave
Site Code:
Start Date: 05/27/2010
Page No: 7

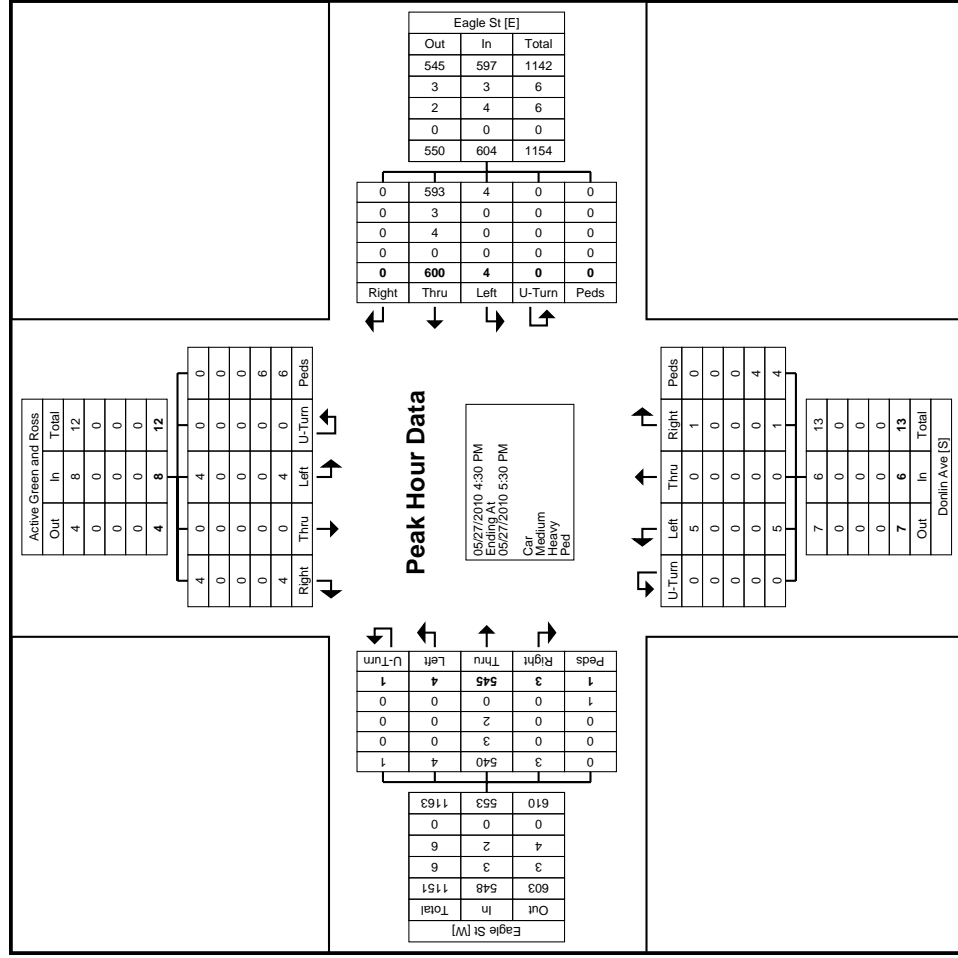

Turning Movement Peak Hour Data Plot (4:30 PM)

Ontario Traffic Inc.

Morning Peak Diagram

Specified Period

From: 7:00:00

To: 9:00:00

One Hour Peak

From: 8:00:00

To: 9:00:00

Municipality: Newmarket
Site #: 0900600039
Intersection: Eagle & Carol
TFR File #: 4
Count date: 14-Oct-09

Weather conditions:

Person(s) who counted:

**** Signalized Intersection ****

Major Road: Eagle runs W/E

North Leg Total: 189
 North Entering: 108
 North Peds: 4
 Peds Cross: \bowtie

Heavys	0	0	1	1
Trucks	0	0	0	0
Cars	41	44	22	107
Totals	41	44	23	



Heavys	0
Trucks	1
Cars	80
Totals	81

East Leg Total: 1115
 East Entering: 499
 East Peds: 5
 Peds Cross: \bowtie

Heavys	Trucks	Cars	Totals
12	8	492	512



Carol

Cars	Trucks	Heavys	Totals
7	0	0	7
408	7	11	426
58	3	5	66
473	10	16	



Eagle

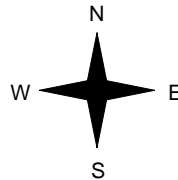

Heavys	Trucks	Cars	Totals
0	0	15	15
6	6	466	478
1	1	29	31
7	7	510	

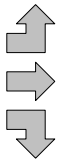

Eagle



Peds Cross: \bowtie
 West Peds: 1
 West Entering: 524
 West Leg Total: 1036

Cars	131	Cars	43	58	110	211
Trucks	4	Trucks	1	1	3	5
Heavys	6	Heavys	1	0	2	3
Totals	141	Totals	45	59	115	



Peds Cross: \bowtie
 South Peds: 5
 South Entering: 219
 South Leg Total: 360

Comments

Ontario Traffic Inc.

Afternoon Peak Diagram

Specified Period

From: 15:00:00

To: 18:00:00

One Hour Peak

From: 16:30:00

To: 17:30:00

Municipality: Newmarket
Site #: 0900600039
Intersection: Eagle & Carol
TFR File #: 4
Count date: 14-Oct-09

Weather conditions:

Person(s) who counted:

**** Signalized Intersection ****

Major Road: Eagle runs W/E

North Leg Total: 298
 North Entering: 153
 North Peds: 4
 Peds Cross: \bowtie

Heavys	0	0	0	0
Trucks	0	0	1	1
Cars	23	92	37	152
Totals	23	92	38	



Heavys	0
Trucks	0
Cars	145
Totals	145

East Leg Total: 1230
 East Entering: 632
 East Peds: 7
 Peds Cross: \bowtie

Heavys	Trucks	Cars	Totals
2	3	595	600



Carol

Cars	Trucks	Heavys	Totals
17	0	0	17
512	3	2	517
97	0	1	98
626	3	3	



Eagle

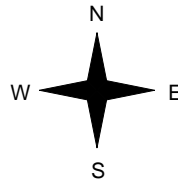

Heavys	Trucks	Cars	Totals
0	0	31	31
3	3	487	493
0	0	62	62
3	3	580	

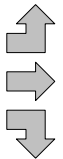

Eagle



Peds Cross: \bowtie
 West Peds: 1
 West Entering: 586
 West Leg Total: 1186

Cars	251
Trucks	0
Heavys	1
Totals	252



Cars	60	97	67	224
Trucks	0	0	0	0
Heavys	0	0	0	0
Totals	60	97	67	

Peds Cross: \bowtie
 South Peds: 7
 South Entering: 224
 South Leg Total: 476

Comments



INTERSECTION NAME: **Eagle St. (YR 5) & Carol / Sandford**

PROGRAMMED BY: **D. Rumble**

CONTROLLER SERIAL #: _____

CTCS #: **532**

ADDRESS: **2**

SECURITY CODE: **1000**

PROGRAM DATE: **Oct 29, 2001**

INSTALLATION DATE: **Oct 29, 2001**

MEMORY/RECALL/CNA (MM-2-2-1)

	1	2	3	4	5	6	7	8
MEMORY	OFF	OFF	OFF	OFF	OFF	OFF	OFF	OFF
EXT RECALL	OFF	OFF	OFF	OFF	OFF	OFF	OFF	OFF
MAX RECALL	OFF	ON	OFF	OFF	OFF	ON	OFF	OFF
PED RECALL	OFF	ON	OFF	OFF	OFF	ON	OFF	OFF
CNA I	OFF	ON	OFF	OFF	OFF	ON	OFF	OFF
CNA II	OFF	OFF	OFF	OFF	OFF	OFF	OFF	OFF
FL WALK	OFF	OFF	OFF	OFF	OFF	OFF	OFF	OFF
SOFT RECALL	OFF	OFF	OFF	OFF	OFF	OFF	OFF	OFF
WALK REST	OFF	ON	OFF	OFF	OFF	ON	OFF	OFF
COND PED	OFF	OFF	OFF	OFF	OFF	OFF	OFF	OFF
FWTPCL	OFF	OFF	OFF	OFF	OFF	OFF	OFF	OFF

- 1 - Not Used
- 2 - Westbound
- 3 - Not Used
- 4 - Southbound
- 5 - Not Used
- 6 - Eastbound
- 7 - Not Used
- 8 - Northbound

PHASES USED (MM-2-2-3-1)

PHASE	1	2	3	4	5	6	7	8
ON/OFF	OFF	ON	OFF	ON	OFF	ON	OFF	ON

SEQUENCE (MM-2-2-3-2)

2	1=Sequential, 2= Dual Ring, 3-7= Spec, 8=Lead/Lag							
---	---	--	--	--	--	--	--	--

LEAD/LAG MODES (MM-2-2-3-2-PGDN....only if Seq = Lead/Lag)

PAIRS	1 AND 2	3 AND 4	5 AND 6	7 AND 8
CODE				

Codes: 1 = No Reversal, 2 = Always Reverse, 3 = Rev. by CSO or Clock

LEAD/LAG BARRIERS (MM-2-2-3-2-PGDN-PGDN....only if lead/lag)

LEAD/LAG BARRIERS ARE: _____ ON/OFF

On = Barriers after each ring 1 and 2 phase pair in a vertical column

SPECIAL INCOMPATIBILITIES (MM-2-2-3-3)

PHASE	1	2	3	4	5	6	7	8
INCOMPAT PH 1-8								
INCOMPAT PH 1-8								

INITIALIZE / FLASH (MM-2-2-4) 1 = RED, 2 = YEL., 3 = GRN

	INITIALIZE	ENTER FL	EXIT FL
RING 1 PHASE	2	2	2
RING 2 PHASE	6	6	6
INTERVAL	2	1	2

NOTE: Enter flash interval is permanently set to 1 (RED)

POWER-UP RESTART TIMINGS (MM-2-2-4-PGDN)

MINIMUM FLASH	(0-9.9 or 127 SECONDS)
1ST ALL RED AFTER FLASH	(0-9.9 or 127 SECONDS)

NOTE: Blanks = 0, OFF, or controller default values

PHASE TIMINGS (MM-2-2-2)

	1	2	3	4	5	6	7	8
MIN GREEN	0	30	0	10	0	30	0	10
PASSAGE	0	0	0	3.0	0	0	0	3.0
YELLOW	0	5.0	0	4.0	0	5.0	0	4.0
RED	0	2.0	0	2.0	0	2.0	0	2.0
MAX I	0	40	0	19	0	40	0	19
MAX II	0	50	0	50	0	50	0	50
WALK	0	7	0	7	0	7	0	7
PED CLEAR	0	13.4	0	9.12	0	13.4	0	9.12
S/A	0	0	0	0	0	0	0	0
TBR	0	0	0	0	0	0	0	0
TTR	0	0	0	0	0	0	0	0
MIN GAP	0	0	0	0	0	0	0	0
MAX VI	0	0	0	0	0	0	0	0
MAX EXT	0	0	0	0	0	0	0	0
AUTO MAX	0	0	0	0	0	0	0	0
AMR	0	0	0	0	0	0	0	0

Range: 0-9.9 or 127 except max times and auto max which are 0 -255 secs.

LOCATION: Yonge St (YR 1) & Eagle St
 300
 CTCS: SA with APS & TSP
 MODE/COMMENT: AM
 PREPARED/CHECKED BY: AM
 PREPARATION DATE:
 IMPLEMENTATION DATE: June 18, 2020

MUNICIPALITY: Newmarket
 COMPUTER SYSTEM: Contracs
 CONTROLLER/CABINET TYPE: Econolite Cobalt / TS2T1
 CONFLICT FLASH: Red & Red
 DESIGN WALK SPEED: 1.0 m/s (FDW based on full crossing at 1.2 m/s)
 CHANNEL/DROP:



NEMA Phase (York)	Local Plan	AM	PM	OFF	Weekend	Free	Phase Mode (Fixed/Demanded/Callable)	Remarks
		6:30-9:00 M-F	16:00-19:00 M-F	9:00-16:00, 19:00-21:30 M-F	9:00-21:30 Sat & Sun	21:30-6:30 M-F, 21:30-9:00 Sat & Sun		
	System Plan	Pattern 1 Plan 1	Pattern 2 Plan 2	Pattern 3 Plan 3	Pattern 4 Plan 4	Pattern 99 Plan 99		
1. N/B Left Turn Arrow (Fully Protected) 	WLK FDW MIN EXT MAX1 MAX2 AMB ALR SPLIT						Fully Protected Callable/Extendable by Stopbar Loop	Emergency vehicle pre-emption 3: Serve SBG/NSDW min 20 secs and up to 100 secs if there are continuous emergency calls in SB direction. Emergency vehicle pre-emption 4: Serve NBG/NSDW min 20 secs and up to 100 secs if there are continuous emergency calls in NB direction.
2. Southbound 	WLK FDW MIN EXT MAX1 MAX2 AMB ALR SPLIT						Fixed SB transit signal (Overlap A) on concurrently with SBG Max Reduction for phase 4 & 8 is 10 secs when bus is slow and very slow	Emergency vehicle pre-emption 5: Serve EBG/EWDW min 20 secs and up to 100 secs if there are continuous emergency calls in EB direction. Emergency vehicle pre-emption 6: Serve WBG/EWDW min 20 secs and up to 100 secs if there are continuous emergency calls in WB direction. EW phase is callable by vehicle or pedestrian actuation. If a vehicle call is received, the minimum EWG is 10 seconds. If ongoing vehicle demand exists on the stopbar loop, the EWG is capable of providing vehicle extensions up to the maximum green split during coordinated operation or 35 secs during Free operation. If a pedestrian call is received, the pedestrian minimum will be served. The EWWK & EWFD are only displayed on the pedestrian signal heads if a pedestrian call is received. Extension time is based on vehicle demand. Unused extension time is given to the NSG.
3. W/B Left Turn Arrow 	WLK FDW MIN EXT MAX1 MAX2 AMB ALR SPLIT						Callable/Extendable by Setback Loop	
4. Eastbound 	WLK FDW MIN EXT MAX1 MAX2 AMB ALR SPLIT						Callable by stopbar loop bike box; and/or pushbutton; Extendable by stopbar loop. Bike Min Green=15 sec	During coordinated operation, the signal constantly cycles through main street FDW to improve response time to side street vehicle and pedestrian demand. During free plan, signal rests in NSWK and does not cycle through NSFD unless there is side street vehicle or pedestrian demand.
5. S/B Left Turn Arrow (Fully Protected) 	WLK FDW MIN EXT MAX1 MAX2 AMB ALR SPLIT						Fully Protected Callable/Extendable by Stopbar Loop	NSFD reverts to NSWK if there is no side street demand at the end of the NSFD. If both SBLA/SB U-Turn and NB U-Turn are called without side street demand, signal will terminate main street green and go to All-Red before serving SBLA/SB U-Turn and NB U-Turn. If only SBLA/SB U-Turn is called without side street demand, signal will terminate NB vehicle green and both NS transit green before serving SBLA/SB U-Turn. No issues with Yellow Trap as the advances are fully protected. If only NBLA/NB U-Turn is called without side street demand, signal will terminate SB vehicle green and both NS transit green before serving NBLA/NB U-Turn. No issues with Yellow Trap as the advances are fully protected. APS Extended Push Activation = 3 sec When activated, APS is on for 7 seconds.
6. Northbound 	WLK FDW MIN EXT MAX1 MAX2 AMB ALR SPLIT						Fixed NB transit signal (Overlap C) on concurrently with NBG Max Reduction for phase 4 & 8 is 10 secs when bus is slow and	
NOT USED 	WLK FDW MIN EXT MAX1 MAX2 AMB ALR SPLIT							LEGEND: SA - Semi-Actuated signal WLK - Walk time FDW - Flashing Don't Walk time MIN - Minimum green time EXT - Extension time MAX1 - Maximum green time 1 MAX2 - Maximum green time 2 AMB - Amber ALR - All Red CL - Cycle Length OF - Offset VP - Vehicle Permissive NSWK - North/South Walk EWWK - East/West Walk NSG - North/South Green EWG - East/West Green NSFD - North/South Flashing Don't Walk EWFD - East/West Flashing Don't Walk TSP - Transit Priority APS - Audible Pedestrian Signal RLC - Red Light Camera
8. Westbound 	WLK FDW MIN EXT MAX1 MAX2 AMB ALR SPLIT						Callable by stopbar loop bike box; and/or pushbutton; Extendable by stopbar loop. Bike Min Green=15 sec	
	CL OF VP	135 109 18	140 100 18	140 81 18	140 119 18	0 (FREE) 0 (FREE) 0 (FREE)		

NOTES:

APPENDIX B

Existing Traffic Level of Service Calculations

Queues

3: Yonge St & Eagle St W/Eagle St

12/23/2020

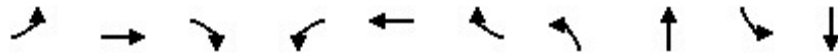

Lane Group	EBL	EBT	EBR	WBL	WBT	WBR	NBL	NBT	SBL	SBT
Lane Group Flow (vph)	55	260	155	141	307	85	238	797	151	804
Act Effct Green (s)	24.1	24.1	24.1	43.2	42.7	42.7	21.5	39.0	17.7	35.2
Actuated g/C Ratio	0.21	0.21	0.21	0.38	0.38	0.38	0.19	0.34	0.16	0.31
v/c Ratio	0.23	0.63	0.33	0.38	0.42	0.13	0.68	0.64	0.53	0.71
Control Delay	40.8	48.7	7.4	27.0	28.5	4.4	55.2	35.4	52.5	40.1
Queue Delay	0.0	0.0	0.0	0.0	0.0	0.0	0.0	0.0	0.0	0.0
Total Delay	40.8	48.7	7.4	27.0	28.5	4.4	55.2	35.4	52.5	40.1
LOS	D	D	A	C	C	A	E	D	D	D
Approach Delay		34.1			24.3			39.9		42.0
Approach LOS		C			C			D		D
Queue Length 50th (m)	10.5	54.6	0.0	21.3	51.4	0.0	50.1	77.0	32.0	84.7
Queue Length 95th (m)	22.4	83.6	15.7	36.4	77.0	8.5	85.2	119.3	55.6	122.3
Internal Link Dist (m)		212.4			147.9			184.0		260.3
Turn Bay Length (m)	171.0		52.0	120.0		55.0	85.0		110.0	
Base Capacity (vph)	391	683	683	389	1029	918	411	1244	411	1188
Starvation Cap Reductn	0	0	0	0	0	0	0	0	0	0
Spillback Cap Reductn	0	0	0	0	0	0	0	0	0	0
Storage Cap Reductn	0	0	0	0	0	0	0	0	0	0
Reduced v/c Ratio	0.14	0.38	0.23	0.36	0.30	0.09	0.58	0.64	0.37	0.68

Intersection Summary

Cycle Length: 135

Actuated Cycle Length: 113.6

Control Type: Semi Act-Uncoord

Maximum v/c Ratio: 0.71

Intersection Signal Delay: 36.9

Intersection LOS: D

Intersection Capacity Utilization 76.0%

ICU Level of Service D

Analysis Period (min) 15

HCM Signalized Intersection Capacity Analysis

3: Yonge St & Eagle St W/Eagle St

12/23/2020

Movement	EBL	EBT	EBR	WBL	WBT	WBR	NBL	NBT	NBR	SBL	SBT	SBR
Lane Configurations												
Traffic Volume (vph)	51	239	143	130	282	78	219	604	129	139	664	75
Future Volume (vph)	51	239	143	130	282	78	219	604	129	139	664	75
Ideal Flow (vphpl)	2000	2000	2000	2000	2000	2000	2000	2000	2000	2000	2000	2000
Total Lost time (s)	5.5	5.5	5.5	5.0	5.5	5.5	3.0	5.5		3.0	5.5	
Lane Util. Factor	1.00	1.00	1.00	1.00	1.00	1.00	1.00	0.95		1.00	0.95	
Frt	1.00	1.00	0.85	1.00	1.00	0.85	1.00	0.97		1.00	0.98	
Flt Protected	0.95	1.00	1.00	0.95	1.00	1.00	0.95	1.00		0.95	1.00	
Satd. Flow (prot)	1842	1939	1648	1842	1939	1648	1842	3587		1842	3628	
Flt Permitted	0.57	1.00	1.00	0.30	1.00	1.00	0.95	1.00		0.95	1.00	
Satd. Flow (perm)	1112	1939	1648	581	1939	1648	1842	3587		1842	3628	
Peak-hour factor, PHF	0.92	0.92	0.92	0.92	0.92	0.92	0.92	0.92	0.92	0.92	0.92	0.92
Adj. Flow (vph)	55	260	155	141	307	85	238	657	140	151	722	82
RTOR Reduction (vph)	0	0	122	0	0	53	0	12	0	0	6	0
Lane Group Flow (vph)	55	260	33	141	307	32	238	785	0	151	798	0
Turn Type	Perm	NA	Perm	pm+pt	NA	Perm	Prot	NA		Prot	NA	
Protected Phases		4		3	8		5	2		1	6	
Permitted Phases	4		4	8		8						
Actuated Green, G (s)	21.1	21.1	21.1	39.6	39.6	39.6	18.5	35.9		14.7	32.1	
Effective Green, g (s)	24.1	24.1	24.1	42.6	42.6	42.6	21.5	38.9		17.7	35.1	
Actuated g/C Ratio	0.21	0.21	0.21	0.38	0.38	0.38	0.19	0.34		0.16	0.31	
Clearance Time (s)	8.5	8.5	8.5	8.0	8.5	8.5	6.0	8.5		6.0	8.5	
Vehicle Extension (s)	3.0	3.0	3.0	3.0	3.0	3.0	3.0	3.0		3.0	3.0	
Lane Grp Cap (vph)	236	412	350	369	729	620	349	1232		288	1124	
v/s Ratio Prot		c0.13		0.05	c0.16		c0.13	0.22		0.08	c0.22	
v/s Ratio Perm	0.05		0.02	0.10		0.02						
v/c Ratio	0.23	0.63	0.09	0.38	0.42	0.05	0.68	0.64		0.52	0.71	
Uniform Delay, d1	36.9	40.5	35.8	24.9	26.2	22.5	42.7	31.2		43.9	34.5	
Progression Factor	1.00	1.00	1.00	1.00	1.00	1.00	1.00	1.00		1.00	1.00	
Incremental Delay, d2	0.5	3.1	0.1	0.7	0.4	0.0	5.4	1.1		1.7	2.1	
Delay (s)	37.4	43.6	35.9	25.6	26.6	22.5	48.1	32.3		45.6	36.6	
Level of Service	D	D	D	C	C	C	D	C		D	D	
Approach Delay (s)		40.4			25.6			35.9			38.0	
Approach LOS		D			C			D			D	
Intersection Summary												
HCM 2000 Control Delay			35.5	HCM 2000 Level of Service				D				
HCM 2000 Volume to Capacity ratio			0.65									
Actuated Cycle Length (s)			113.2	Sum of lost time (s)				19.0				
Intersection Capacity Utilization			76.0%	ICU Level of Service				D				
Analysis Period (min)			15									
c Critical Lane Group												

HCM Unsignalized Intersection Capacity Analysis

6: Dixon Blvd & Eagle St

12/23/2020



Movement	EBT	EBR	WBL	WBT	NBL	NBR
Lane Configurations	→			←	↔	↔
Traffic Volume (veh/h)	507	16	11	460	26	24
Future Volume (Veh/h)	507	16	11	460	26	24
Sign Control	Free			Free	Stop	
Grade	0%			0%	0%	
Peak Hour Factor	0.92	0.92	0.92	0.92	0.92	0.92
Hourly flow rate (vph)	551	17	12	500	28	26
Pedestrians						
Lane Width (m)						
Walking Speed (m/s)						
Percent Blockage						
Right turn flare (veh)						
Median type	None			None		
Median storage veh						
Upstream signal (m)	172					
pX, platoon unblocked			0.88		0.88	0.88
vC, conflicting volume			568		1084	560
vC1, stage 1 conf vol						
vC2, stage 2 conf vol						
vCu, unblocked vol			436		1025	427
tC, single (s)			4.1		6.4	6.2
tC, 2 stage (s)						
tF (s)			2.2		3.5	3.3
p0 queue free %			99		88	95
cM capacity (veh/h)			984		225	550
Direction, Lane #	EB 1	WB 1	NB 1			
Volume Total	568	512	54			
Volume Left	0	12	28			
Volume Right	17	0	26			
cSH	1700	984	315			
Volume to Capacity	0.33	0.01	0.17			
Queue Length 95th (m)	0.0	0.3	4.6			
Control Delay (s)	0.0	0.4	18.8			
Lane LOS		A	C			
Approach Delay (s)	0.0	0.4	18.8			
Approach LOS			C			
Intersection Summary						
Average Delay			1.1			
Intersection Capacity Utilization			41.4%	ICU Level of Service	A	
Analysis Period (min)			15			

HCM Unsignalized Intersection Capacity Analysis

8: Donlin Ave & Eagle St

12/23/2020



Movement	EBT	EBR	WBL	WBT	NBL	NBR
Lane Configurations	→			←	↘	↙
Traffic Volume (veh/h)	545	3	0	501	1	2
Future Volume (Veh/h)	545	3	0	501	1	2
Sign Control	Free			Free	Stop	
Grade	0%			0%	0%	
Peak Hour Factor	0.92	0.92	0.92	0.92	0.92	0.92
Hourly flow rate (vph)	592	3	0	545	1	2
Pedestrians						
Lane Width (m)						
Walking Speed (m/s)						
Percent Blockage						
Right turn flare (veh)						
Median type	None		None			
Median storage veh						
Upstream signal (m)	287					
pX, platoon unblocked					0.93	
vC, conflicting volume			595	1138	594	
vC1, stage 1 conf vol						
vC2, stage 2 conf vol						
vCu, unblocked vol			595	1112	594	
tC, single (s)			4.1	6.4	6.2	
tC, 2 stage (s)						
tF (s)			2.2	3.5	3.3	
p0 queue free %			100	100	100	
cM capacity (veh/h)			981	215	505	
Direction, Lane #	EB 1	WB 1	NB 1			
Volume Total	595	545	3			
Volume Left	0	0	1			
Volume Right	3	0	2			
cSH	1700	981	349			
Volume to Capacity	0.35	0.00	0.01			
Queue Length 95th (m)	0.0	0.0	0.2			
Control Delay (s)	0.0	0.0	15.4			
Lane LOS			C			
Approach Delay (s)	0.0	0.0	15.4			
Approach LOS			C			
Intersection Summary						
Average Delay			0.0			
Intersection Capacity Utilization			37.4%	ICU Level of Service	A	
Analysis Period (min)			15			

Queues

10: Sanford st/Carol Ave & Eagle St

12/23/2020

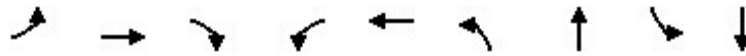

Lane Group	EBL	EBT	EBR	WBL	WBT	NBL	NBT	SBL	SBT
Lane Group Flow (vph)	17	573	36	75	495	51	199	26	100
Act Effect Green (s)	33.0	33.0	33.0	33.0	33.0	13.7	13.7	13.7	13.7
Actuated g/C Ratio	0.61	0.61	0.61	0.61	0.61	0.26	0.26	0.26	0.26
v/c Ratio	0.03	0.48	0.03	0.17	0.42	0.15	0.37	0.10	0.20
Control Delay	4.7	7.6	1.4	6.0	6.9	16.7	8.7	16.2	10.7
Queue Delay	0.0	0.0	0.0	0.0	0.0	0.0	0.0	0.0	0.0
Total Delay	4.7	7.6	1.4	6.0	6.9	16.7	8.7	16.2	10.7
LOS	A	A	A	A	A	B	A	B	B
Approach Delay		7.1			6.7		10.3		11.9
Approach LOS		A			A		B		B
Queue Length 50th (m)	0.5	24.0	0.0	2.5	19.6	3.8	5.0	1.9	3.9
Queue Length 95th (m)	2.6	50.0	2.1	8.2	40.9	10.5	17.6	6.6	12.7
Internal Link Dist (m)		263.5			65.3		306.7		229.9
Turn Bay Length (m)	86.0		32.0			50.0		58.0	
Base Capacity (vph)	554	1301	1122	483	1298	550	794	431	766
Starvation Cap Reductn	0	0	0	0	0	0	0	0	0
Spillback Cap Reductn	0	0	0	0	0	0	0	0	0
Storage Cap Reductn	0	0	0	0	0	0	0	0	0
Reduced v/c Ratio	0.03	0.44	0.03	0.16	0.38	0.09	0.25	0.06	0.13

Intersection Summary

Cycle Length: 65

Actuated Cycle Length: 53.7

Control Type: Semi Act-Uncoord

Maximum v/c Ratio: 0.48

Intersection Signal Delay: 7.9

Intersection LOS: A

Intersection Capacity Utilization 80.1%

ICU Level of Service D

Analysis Period (min) 15

HCM Signalized Intersection Capacity Analysis

10: Sanford st/Carol Ave & Eagle St

12/23/2020



Movement	EBL	EBT	EBR	WBL	WBT	WBR	NBL	NBT	NBR	SBL	SBT	SBR
Lane Configurations												
Traffic Volume (vph)	16	527	33	69	448	7	47	62	121	24	49	43
Future Volume (vph)	16	527	33	69	448	7	47	62	121	24	49	43
Ideal Flow (vphpl)	2000	2000	2000	2000	2000	2000	2000	2000	2000	2000	2000	2000
Total Lost time (s)	4.0	4.0	4.0	4.0	4.0		3.0	3.0		3.0	3.0	
Lane Util. Factor	1.00	1.00	1.00	1.00	1.00		1.00	1.00		1.00	1.00	
Frt	1.00	1.00	0.85	1.00	1.00		1.00	0.90		1.00	0.93	
Flt Protected	0.95	1.00	1.00	0.95	1.00		0.95	1.00		0.95	1.00	
Satd. Flow (prot)	1842	1939	1648	1842	1934		1842	1746		1842	1802	
Flt Permitted	0.43	1.00	1.00	0.37	1.00		0.69	1.00		0.54	1.00	
Satd. Flow (perm)	826	1939	1648	721	1934		1342	1746		1050	1802	
Peak-hour factor, PHF	0.92	0.92	0.92	0.92	0.92	0.92	0.92	0.92	0.92	0.92	0.92	0.92
Adj. Flow (vph)	17	573	36	75	487	8	51	67	132	26	53	47
RTOR Reduction (vph)	0	0	14	0	1	0	0	98	0	0	35	0
Lane Group Flow (vph)	17	573	22	75	494	0	51	101	0	26	65	0
Turn Type	Perm	NA	Perm	Perm	NA		Perm	NA		Perm	NA	
Protected Phases		4			8			2			6	
Permitted Phases	4		4	8			2			6		
Actuated Green, G (s)	30.0	30.0	30.0	30.0	30.0		10.7	10.7		10.7	10.7	
Effective Green, g (s)	33.0	33.0	33.0	33.0	33.0		13.7	13.7		13.7	13.7	
Actuated g/C Ratio	0.61	0.61	0.61	0.61	0.61		0.26	0.26		0.26	0.26	
Clearance Time (s)	7.0	7.0	7.0	7.0	7.0		6.0	6.0		6.0	6.0	
Vehicle Extension (s)	3.0	3.0	3.0	3.0	3.0		3.0	3.0		3.0	3.0	
Lane Grp Cap (vph)	507	1191	1012	443	1188		342	445		267	459	
v/s Ratio Prot		c0.30			0.26			c0.06			0.04	
v/s Ratio Perm	0.02		0.01	0.10			0.04			0.02		
v/c Ratio	0.03	0.48	0.02	0.17	0.42		0.15	0.23		0.10	0.14	
Uniform Delay, d1	4.1	5.7	4.0	4.5	5.4		15.5	15.8		15.3	15.5	
Progression Factor	1.00	1.00	1.00	1.00	1.00		1.00	1.00		1.00	1.00	
Incremental Delay, d2	0.0	0.3	0.0	0.2	0.2		0.2	0.3		0.2	0.1	
Delay (s)	4.1	6.0	4.1	4.6	5.6		15.7	16.1		15.4	15.6	
Level of Service	A	A	A	A	A		B	B		B	B	
Approach Delay (s)		5.8			5.5			16.0			15.6	
Approach LOS		A			A			B			B	

Intersection Summary

HCM 2000 Control Delay	8.1	HCM 2000 Level of Service	A
HCM 2000 Volume to Capacity ratio	0.41		
Actuated Cycle Length (s)	53.7	Sum of lost time (s)	7.0
Intersection Capacity Utilization	80.1%	ICU Level of Service	D
Analysis Period (min)	15		

c Critical Lane Group

Queues

3: Yonge St & Eagle St W/Eagle St

12/23/2020

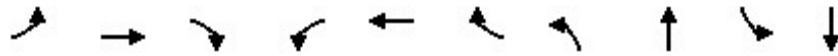

Lane Group	EBL	EBT	EBR	WBL	WBT	WBR	NBL	NBT	SBL	SBT
Lane Group Flow (vph)	65	284	237	166	330	120	153	1084	148	797
Act Effct Green (s)	24.3	27.4	24.3	42.2	41.7	41.7	17.3	42.7	17.2	42.5
Actuated g/C Ratio	0.20	0.23	0.20	0.35	0.35	0.35	0.14	0.36	0.14	0.35
v/c Ratio	0.30	0.64	0.46	0.61	0.49	0.18	0.58	0.84	0.56	0.61
Control Delay	45.9	49.9	9.0	39.8	34.6	5.6	59.8	42.6	59.5	34.9
Queue Delay	0.0	0.0	0.0	0.0	0.0	0.0	0.0	0.0	0.0	0.0
Total Delay	45.9	49.9	9.0	39.8	34.6	5.6	59.8	42.6	59.5	34.9
LOS	D	D	A	D	C	A	E	D	E	C
Approach Delay		32.9			30.3			44.8		38.8
Approach LOS		C			C			D		D
Queue Length 50th (m)	13.6	63.5	1.8	29.2	64.1	0.0	34.9	122.0	33.8	81.4
Queue Length 95th (m)	27.5	95.2	22.4	48.2	95.1	12.6	63.1	171.7	61.2	116.7
Internal Link Dist (m)		212.4			146.8			184.0		260.3
Turn Bay Length (m)	171.0		52.0	120.0		55.0	85.0		110.0	
Base Capacity (vph)	338	652	669	272	883	816	313	1499	313	1514
Starvation Cap Reductn	0	0	0	0	0	0	0	0	0	0
Spillback Cap Reductn	0	0	0	0	0	0	0	0	0	0
Storage Cap Reductn	0	0	0	0	0	0	0	0	0	0
Reduced v/c Ratio	0.19	0.44	0.35	0.61	0.37	0.15	0.49	0.72	0.47	0.53

Intersection Summary

Cycle Length: 140

Actuated Cycle Length: 119.9

Control Type: Semi Act-Uncoord

Maximum v/c Ratio: 0.84

Intersection Signal Delay: 38.4

Intersection LOS: D

Intersection Capacity Utilization 80.3%

ICU Level of Service D

Analysis Period (min) 15

HCM Signalized Intersection Capacity Analysis

3: Yonge St & Eagle St W/Eagle St

12/23/2020

Movement	EBL	EBT	EBR	WBL	WBT	WBR	NBL	NBT	NBR	SBL	SBT	SBR	
Lane Configurations													
Traffic Volume (vph)	60	261	218	153	304	110	141	863	134	136	702	31	
Future Volume (vph)	60	261	218	153	304	110	141	863	134	136	702	31	
Ideal Flow (vphpl)	2000	2000	2000	2000	2000	2000	2000	2000	2000	2000	2000	2000	
Total Lost time (s)	8.5	5.5	8.5	7.0	7.5	7.5	3.0	7.5		3.0	7.5		
Lane Util. Factor	1.00	1.00	1.00	1.00	1.00	1.00	1.00	0.95		1.00	0.95		
Frt	1.00	1.00	0.85	1.00	1.00	0.85	1.00	0.98		1.00	0.99		
Flt Protected	0.95	1.00	1.00	0.95	1.00	1.00	0.95	1.00		0.95	1.00		
Satd. Flow (prot)	1842	1939	1648	1842	1939	1648	1842	3610		1842	3661		
Flt Permitted	0.56	1.00	1.00	0.25	1.00	1.00	0.95	1.00		0.95	1.00		
Satd. Flow (perm)	1089	1939	1648	479	1939	1648	1842	3610		1842	3661		
Peak-hour factor, PHF	0.92	0.92	0.92	0.92	0.92	0.92	0.92	0.92	0.92	0.92	0.92	0.92	
Adj. Flow (vph)	65	284	237	166	330	120	153	938	146	148	763	34	
RTOR Reduction (vph)	0	0	181	0	0	78	0	9	0	0	2	0	
Lane Group Flow (vph)	65	284	56	166	330	42	153	1075	0	148	795	0	
Turn Type	Perm	NA	Perm	pm+pt	NA	Perm	Prot	NA		Prot	NA		
Protected Phases		4		3	8		5	2		1	6		
Permitted Phases	4		4	8		8							
Actuated Green, G (s)	24.4	24.4	24.4	40.6	40.6	40.6	14.3	41.7		14.1	41.5		
Effective Green, g (s)	24.4	27.4	24.4	41.6	41.6	41.6	17.3	42.7		17.1	42.5		
Actuated g/C Ratio	0.20	0.23	0.20	0.35	0.35	0.35	0.14	0.36		0.14	0.36		
Clearance Time (s)	8.5	8.5	8.5	8.0	8.5	8.5	6.0	8.5		6.0	8.5		
Vehicle Extension (s)	3.0	3.0	3.0	3.0	3.0	3.0	3.0	3.0		3.0	3.0		
Lane Grp Cap (vph)	222	444	336	271	675	574	266	1291		263	1303		
v/s Ratio Prot		c0.15		0.05	c0.17		c0.08	c0.30		0.08	0.22		
v/s Ratio Perm	0.06		0.03	0.17		0.03							
v/c Ratio	0.29	0.64	0.17	0.61	0.49	0.07	0.58	0.83		0.56	0.61		
Uniform Delay, d1	40.2	41.5	39.1	29.6	30.6	26.0	47.6	35.1		47.7	31.6		
Progression Factor	1.00	1.00	1.00	1.00	1.00	1.00	1.00	1.00		1.00	1.00		
Incremental Delay, d2	0.7	3.0	0.2	4.1	0.6	0.1	3.0	4.8		2.7	0.9		
Delay (s)	40.9	44.6	39.3	33.6	31.1	26.1	50.6	39.8		50.4	32.5		
Level of Service	D	D	D	C	C	C	D	D		D	C		
Approach Delay (s)		42.1			30.8			41.2			35.3		
Approach LOS		D			C			D			D		
Intersection Summary													
HCM 2000 Control Delay			37.8									HCM 2000 Level of Service	D
HCM 2000 Volume to Capacity ratio			0.72										
Actuated Cycle Length (s)			119.4									Sum of lost time (s)	23.0
Intersection Capacity Utilization			80.3%									ICU Level of Service	D
Analysis Period (min)			15										
c Critical Lane Group													

HCM Unsignalized Intersection Capacity Analysis

6: Dixon Blvd & Eagle St

12/23/2020



Movement	EBT	EBR	WBL	WBT	NBL	NBR
Lane Configurations	→	↘	↙	←	↘	↙
Traffic Volume (veh/h)	531	41	23	626	20	21
Future Volume (Veh/h)	531	41	23	626	20	21
Sign Control	Free			Free	Stop	
Grade	0%			0%	0%	
Peak Hour Factor	0.92	0.92	0.92	0.92	0.92	0.92
Hourly flow rate (vph)	577	45	25	680	22	23
Pedestrians						
Lane Width (m)						
Walking Speed (m/s)						
Percent Blockage						
Right turn flare (veh)						
Median type	None			None		
Median storage veh						
Upstream signal (m)	171					
pX, platoon unblocked			0.86		0.86	0.86
vC, conflicting volume			622		1330	600
vC1, stage 1 conf vol						
vC2, stage 2 conf vol						
vCu, unblocked vol			485		1303	459
tC, single (s)			4.1		6.4	6.2
tC, 2 stage (s)						
tF (s)			2.2		3.5	3.3
p0 queue free %			97		85	96
cM capacity (veh/h)			932		149	521
Direction, Lane #	EB 1	WB 1	NB 1			
Volume Total	622	705	45			
Volume Left	0	25	22			
Volume Right	45	0	23			
cSH	1700	932	235			
Volume to Capacity	0.37	0.03	0.19			
Queue Length 95th (m)	0.0	0.6	5.3			
Control Delay (s)	0.0	0.7	23.9			
Lane LOS		A	C			
Approach Delay (s)	0.0	0.7	23.9			
Approach LOS			C			
Intersection Summary						
Average Delay			1.1			
Intersection Capacity Utilization			59.0%		ICU Level of Service	
Analysis Period (min)			15			
			B			

HCM Unsignalized Intersection Capacity Analysis

8: Donlin Ave & Eagle St

12/23/2020

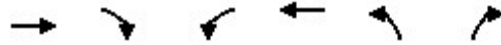

Movement	EBT	EBR	WBL	WBT	NBL	NBR
Lane Configurations						
Traffic Volume (veh/h)	581	3	4	590	0	51
Future Volume (Veh/h)	581	3	4	590	0	51
Sign Control	Free			Free	Stop	
Grade	0%			0%	0%	
Peak Hour Factor	0.92	0.92	0.92	0.92	0.92	0.92
Hourly flow rate (vph)	632	3	4	641	0	55
Pedestrians						
Lane Width (m)						
Walking Speed (m/s)						
Percent Blockage						
Right turn flare (veh)						
Median type	None			None		
Median storage veh						
Upstream signal (m)	230					
pX, platoon unblocked					0.80	
vC, conflicting volume			635	1282	634	
vC1, stage 1 conf vol						
vC2, stage 2 conf vol						
vCu, unblocked vol			635	1227	634	
tC, single (s)			4.1	6.4	6.2	
tC, 2 stage (s)						
tF (s)			2.2	3.5	3.3	
p0 queue free %			100	100	89	
cM capacity (veh/h)			948	156	479	
Direction, Lane #	EB 1	WB 1	NB 1			
Volume Total	635	645	55			
Volume Left	0	4	0			
Volume Right	3	0	55			
cSH	1700	948	479			
Volume to Capacity	0.37	0.00	0.11			
Queue Length 95th (m)	0.0	0.1	2.9			
Control Delay (s)	0.0	0.1	13.5			
Lane LOS			A	B		
Approach Delay (s)	0.0	0.1	13.5			
Approach LOS			B			
Intersection Summary						
Average Delay			0.6			
Intersection Capacity Utilization			42.5%	ICU Level of Service	A	
Analysis Period (min)			15			

Queues

10: Sanford St/Carol Ave & Eagle St

12/23/2020

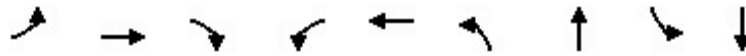

Lane Group	EBL	EBT	EBR	WBL	WBT	NBL	NBT	SBL	SBT
Lane Group Flow (vph)	36	563	71	112	616	68	187	43	137
Act Effct Green (s)	30.6	30.6	30.6	30.6	30.6	11.1	11.1	11.1	11.1
Actuated g/C Ratio	0.56	0.56	0.56	0.56	0.56	0.20	0.20	0.20	0.20
v/c Ratio	0.09	0.52	0.07	0.26	0.57	0.26	0.45	0.17	0.35
Control Delay	6.9	9.9	2.2	8.7	10.6	21.3	17.7	20.0	19.1
Queue Delay	0.0	0.0	0.0	0.0	0.0	0.0	0.0	0.0	0.0
Total Delay	6.9	9.9	2.2	8.7	10.6	21.3	17.7	20.0	19.1
LOS	A	A	A	A	B	C	B	B	B
Approach Delay		8.9			10.3		18.7		19.3
Approach LOS		A			B		B		B
Queue Length 50th (m)	1.4	28.6	0.0	4.7	32.3	5.6	11.2	3.5	10.0
Queue Length 95th (m)	5.5	60.0	4.4	14.4	67.9	14.9	26.9	10.5	23.1
Internal Link Dist (m)		206.0			73.5		168.7		142.5
Turn Bay Length (m)	83.0		32.0			55.0		58.0	
Base Capacity (vph)	413	1172	1024	461	1167	451	669	431	668
Starvation Cap Reductn	0	0	0	0	0	0	0	0	0
Spillback Cap Reductn	0	0	0	0	0	0	0	0	0
Storage Cap Reductn	0	0	0	0	0	0	0	0	0
Reduced v/c Ratio	0.09	0.48	0.07	0.24	0.53	0.15	0.28	0.10	0.21

Intersection Summary

Cycle Length: 65

Actuated Cycle Length: 54.7

Control Type: Semi Act-Uncoord

Maximum v/c Ratio: 0.57

Intersection Signal Delay: 11.9

Intersection LOS: B

Intersection Capacity Utilization 92.6%

ICU Level of Service F

Analysis Period (min) 15

HCM Signalized Intersection Capacity Analysis
 10: Sanford St/Carol Ave & Eagle St

12/23/2020

Movement	EBL	EBT	EBR	WBL	WBT	WBR	NBL	NBT	NBR	SBL	SBT	SBR
Lane Configurations												
Traffic Volume (vph)	33	518	65	103	548	18	63	102	70	40	102	24
Future Volume (vph)	33	518	65	103	548	18	63	102	70	40	102	24
Ideal Flow (vphpl)	2000	2000	2000	2000	2000	2000	2000	2000	2000	2000	2000	2000
Total Lost time (s)	7.0	7.0	7.0	7.0	7.0		6.0	6.0		6.0	6.0	
Lane Util. Factor	1.00	1.00	1.00	1.00	1.00		1.00	1.00		1.00	1.00	
Frt	1.00	1.00	0.85	1.00	1.00		1.00	0.94		1.00	0.97	
Flt Protected	0.95	1.00	1.00	0.95	1.00		0.95	1.00		0.95	1.00	
Satd. Flow (prot)	1842	1939	1648	1842	1930		1842	1821		1842	1884	
Flt Permitted	0.35	1.00	1.00	0.39	1.00		0.67	1.00		0.64	1.00	
Satd. Flow (perm)	685	1939	1648	764	1930		1298	1821		1240	1884	
Peak-hour factor, PHF	0.92	0.92	0.92	0.92	0.92	0.92	0.92	0.92	0.92	0.92	0.92	0.92
Adj. Flow (vph)	36	563	71	112	596	20	68	111	76	43	111	26
RTOR Reduction (vph)	0	0	31	0	2	0	0	43	0	0	14	0
Lane Group Flow (vph)	36	563	40	112	614	0	68	144	0	43	123	0
Turn Type	Perm	NA	Perm	Perm	NA		Perm	NA		Perm	NA	
Protected Phases		4			8			2			6	
Permitted Phases	4		4	8			2			6		
Actuated Green, G (s)	30.6	30.6	30.6	30.6	30.6		11.1	11.1		11.1	11.1	
Effective Green, g (s)	30.6	30.6	30.6	30.6	30.6		11.1	11.1		11.1	11.1	
Actuated g/C Ratio	0.56	0.56	0.56	0.56	0.56		0.20	0.20		0.20	0.20	
Clearance Time (s)	7.0	7.0	7.0	7.0	7.0		6.0	6.0		6.0	6.0	
Vehicle Extension (s)	3.0	3.0	3.0	3.0	3.0		3.0	3.0		3.0	3.0	
Lane Grp Cap (vph)	383	1084	921	427	1079		263	369		251	382	
v/s Ratio Prot		0.29			c0.32			c0.08			0.07	
v/s Ratio Perm	0.05		0.02	0.15			0.05			0.03		
v/c Ratio	0.09	0.52	0.04	0.26	0.57		0.26	0.39		0.17	0.32	
Uniform Delay, d1	5.6	7.5	5.4	6.2	7.8		18.3	18.9		18.0	18.6	
Progression Factor	1.00	1.00	1.00	1.00	1.00		1.00	1.00		1.00	1.00	
Incremental Delay, d2	0.1	0.4	0.0	0.3	0.7		0.5	0.7		0.3	0.5	
Delay (s)	5.7	7.9	5.5	6.6	8.5		18.9	19.6		18.3	19.1	
Level of Service	A	A	A	A	A		B	B		B	B	
Approach Delay (s)		7.5			8.2			19.4			18.9	
Approach LOS		A			A			B			B	

Intersection Summary

HCM 2000 Control Delay	10.6	HCM 2000 Level of Service	B
HCM 2000 Volume to Capacity ratio	0.52		
Actuated Cycle Length (s)	54.7	Sum of lost time (s)	13.0
Intersection Capacity Utilization	92.6%	ICU Level of Service	F
Analysis Period (min)	15		

c Critical Lane Group

APPENDIX C

TTS Data Extraction

Current Development Applications

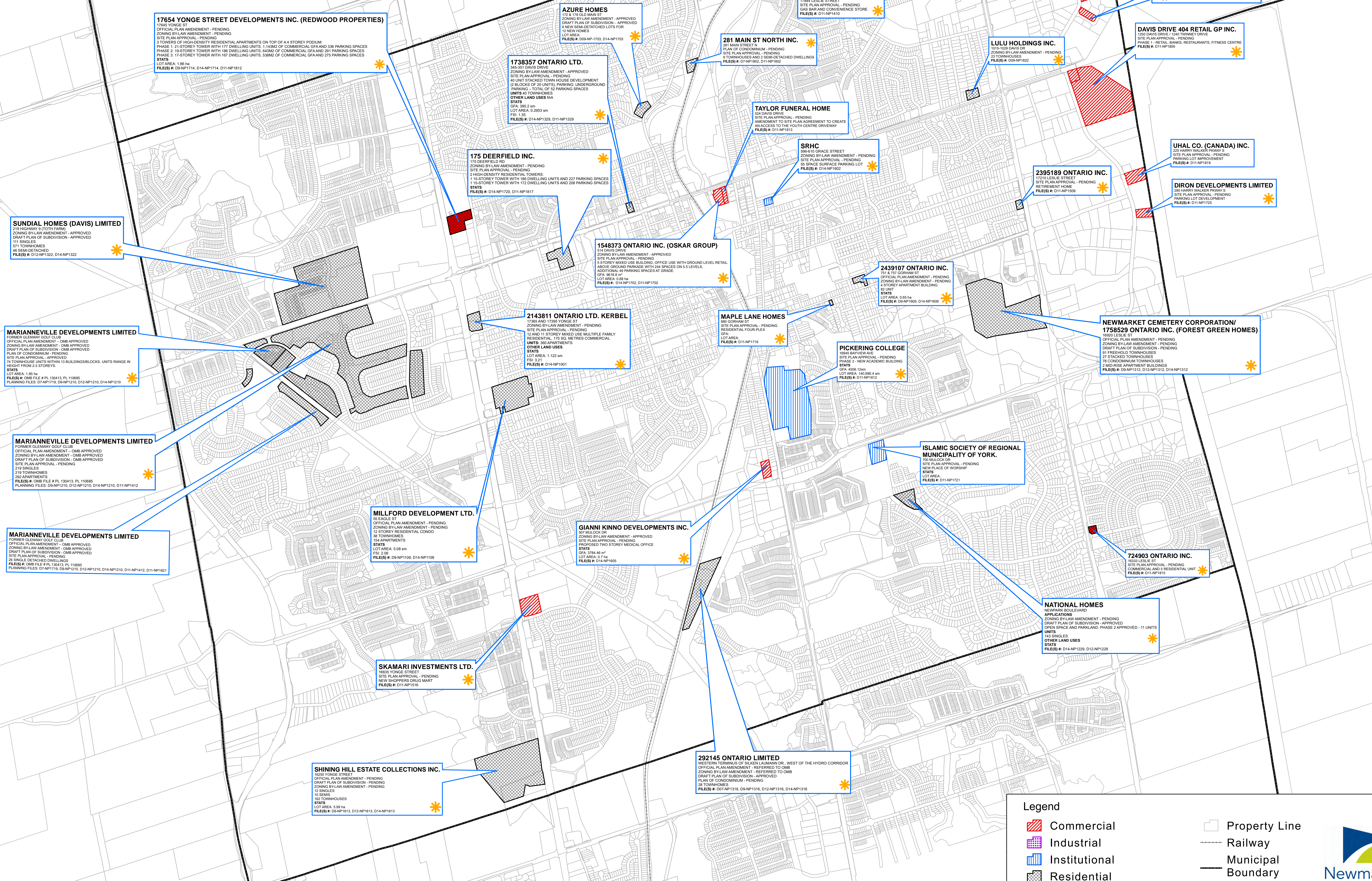
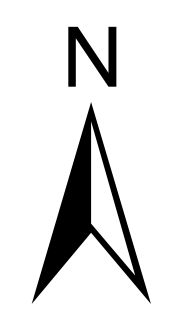

17654 YONGE STREET DEVELOPMENTS INC. (REDWOOD PROPERTIES)
 1765 YONGE ST
 ZONING BY-LAW AMENDMENT - PENDING
 OFFICIAL PLAN AMENDMENT - PENDING
 SITE PLAN APPROVAL - PENDING
 3 TOWERS OF HIGH-DENSITY RESIDENTIAL APARTMENTS ON TOP OF A 4 STOREY POOLUM
 PHASE 1: 21-STORY TOWER WITH 177 DWELLING UNITS, 1,143M² OF COMMERCIAL GFA AND 336 PARKING SPACES
 PHASE 2: 18-STORY TOWER WITH 186 DWELLING UNITS, 840M² OF COMMERCIAL GFA AND 281 PARKING SPACES
 PHASE 3: 17-STORY TOWER WITH 167 DWELLING UNITS, 538M² OF COMMERCIAL GFA AND 275 PARKING SPACES
 STATS
 LOT AREA: 1.86 ha
 FILE(S) #: D9-NP1714, D14-NP1714, D11-NP1812

1738357 ONTARIO LTD.
 345-351 DAVIS DRIVE
 ZONING BY-LAW AMENDMENT - APPROVED
 DRAFT PLAN OF SUBDIVISION - APPROVED
 40 UNIT STACKED TOWN HOUSE DEVELOPMENT
 (2 BLOCKS OF 20 UNITS), PARKING, UNDERGROUND
 PARKING - TOTAL OF 52 PARKING SPACES
 UNITS: 40 TOWNHOUSES
 OTHER LAND USES: N/A
 STATS
 GFA: 392.2 sqm
 LOT AREA: 0.2933 ha
 FSI: 1.35
 FILE(S) #: D14-NP1329, D11-NP1329

175 DEERFIELD INC.
 175 DEERFIELD RD
 ZONING BY-LAW AMENDMENT - PENDING
 OFFICIAL PLAN AMENDMENT - PENDING
 2 HIGH-DENSITY RESIDENTIAL TOWERS:
 1: 14-STORY TOWER WITH 186 DWELLING UNITS AND 227 PARKING SPACES
 2: 11-STORY TOWER WITH 172 DWELLING UNITS AND 208 PARKING SPACES
 STATS
 FILE(S) #: D14-NP1720, D11-NP1817

SUNDIAL HOMES (DAVIS) LIMITED
 211 HURONWAY 71/1011 FARM
 ZONING BY-LAW AMENDMENT - APPROVED
 DRAFT PLAN OF SUBDIVISION - APPROVED
 111 SINGLES
 271 TOWNHOUSES
 46 SEMI-DETACHED
 FILE(S) #: D12-NP1322, D14-NP1322

MARIANVILLE DEVELOPMENTS LIMITED
 FORMER GLENWAY GOLF CLUB
 OFFICIAL PLAN AMENDMENT - OMB APPROVED
 ZONING BY-LAW AMENDMENT - OMB APPROVED
 DRAFT PLAN OF SUBDIVISION - OMB APPROVED
 PLAN OF CONDOMINIUM - PENDING
 SITE PLAN APPROVAL - PENDING
 74 TOWNHOUSE UNITS WITHIN 13 BUILDING BLOCKS, UNITS RANGE IN HEIGHT FROM 3 TO 5 STOREYS
 STATS
 LOT AREA: 1.85 ha
 FILE(S) #: OMB FILE # PL 130413, PL 110685
 PLANNING FILES: D9-NP1718, D9-NP1720, D12-NP1210, D14-NP1210

MARIANVILLE DEVELOPMENTS LIMITED
 FORMER GLENWAY GOLF CLUB
 OFFICIAL PLAN AMENDMENT - OMB APPROVED
 ZONING BY-LAW AMENDMENT - OMB APPROVED
 DRAFT PLAN OF SUBDIVISION - OMB APPROVED
 SITE PLAN APPROVAL - PENDING
 219 SINGLES
 232 TOWNHOUSES
 202 APARTMENTS
 FILE(S) #: OMB FILE # PL 130413, PL 110685
 PLANNING FILES: D9-NP1210, D12-NP1210, D14-NP1210, D11-NP1412

MARIANVILLE DEVELOPMENTS LIMITED
 FORMER GLENWAY GOLF CLUB
 OFFICIAL PLAN AMENDMENT - OMB APPROVED
 ZONING BY-LAW AMENDMENT - OMB APPROVED
 DRAFT PLAN OF SUBDIVISION - OMB APPROVED
 SITE PLAN APPROVAL - PENDING
 26 SINGLE DETACHED DWELLINGS
 FILE(S) #: OMB FILE # PL 130413, PL 110685
 PLANNING FILES: D9-NP1718, D9-NP1720, D12-NP1210, D14-NP1210, D11-NP1412, D11-NP1821

MILL FORD DEVELOPMENT LTD.
 12 KAGLE LT
 OFFICIAL PLAN AMENDMENT - PENDING
 ZONING BY-LAW AMENDMENT - PENDING
 12 STOREY RESIDENTIAL CONDO
 38 TOWNHOUSES
 154 APARTMENTS
 STATS
 LOT AREA: 5.08 ha
 FSI: 2.06
 FILE(S) #: D9-NP1109, D14-NP1109

GIANNI KINNO DEVELOPMENTS INC.
 207 MILLCOCK DR
 ZONING BY-LAW AMENDMENT - APPROVED
 OFFICIAL PLAN AMENDMENT - APPROVED
 SITE PLAN APPROVAL - PENDING
 PROPOSED TWO STOREY MEDICAL OFFICE
 STATS
 GFA: 3784.48 m²
 LOT AREA: 0.7 ha
 FILE(S) #: D14-NP1605

SKAMARI INVESTMENTS LTD.
 1025 YONGE STREET
 SITE PLAN APPROVAL - PENDING
 NEW SHOPREX DRUG MART
 FILE(S) #: D11-NP1516

SHINING HILL ESTATE COLLECTIONS INC.
 1025 YONGE STREET
 OFFICIAL PLAN AMENDMENT - PENDING
 DRAFT PLAN OF SUBDIVISION - PENDING
 ZONING BY-LAW AMENDMENT - PENDING
 10 SINGLES
 182 TOWNHOUSES
 182 TOWNHOUSES
 STATS
 LOT AREA: 5.99 ha
 FILE(S) #: D9-NP1813, D12-NP1813, D14-NP1813

292145 ONTARIO LIMITED
 WESTERN TERMINUS OF SILVEN LAUMANN DR., WEST OF THE HYDRO CORRIDOR
 OFFICIAL PLAN AMENDMENT - REFERRED TO OMB
 ZONING BY-LAW AMENDMENT - REFERRED TO OMB
 DRAFT PLAN OF SUBDIVISION - APPROVED
 PLAN OF CONDOMINIUM - PENDING
 25 TOWNHOUSES
 FILE(S) #: D07-NP1316, D9-NP1316, D12-NP1316, D14-NP1316

Legend

- Commercial
- Industrial
- Institutional
- Residential
- Residential/Commercial
- Property Line
- Railway
- Municipal Boundary

Updated: January 2019

Yonge st

TOTAL EB AM PEAK HOUR

2006	2007	2008	2009	2010
32814	34742	31387	35370	31485

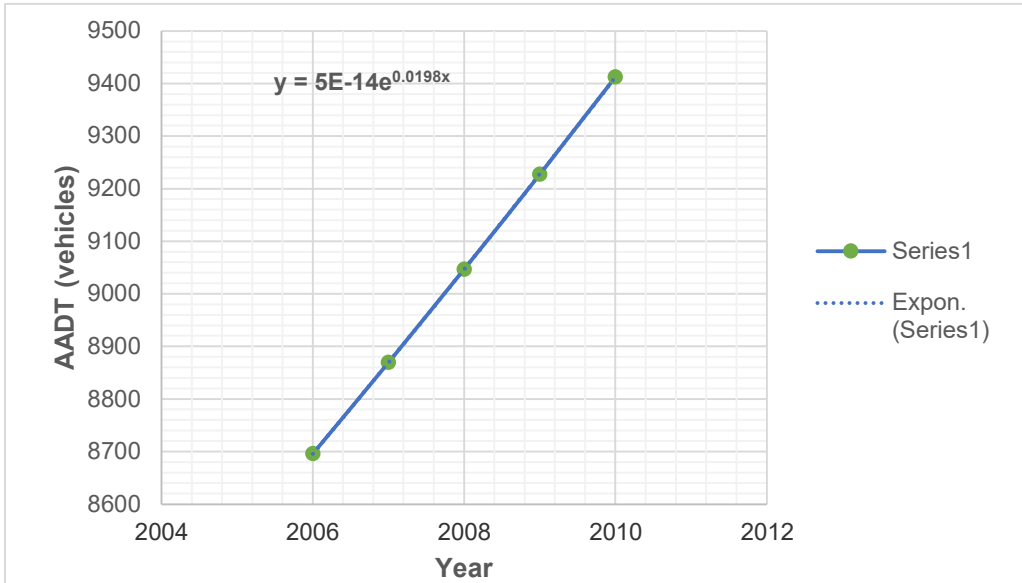

Eagle

TOTAL EB AM PEAK HOUR

2006	2007	2008	2009	2010	2011
8696	8870	9047	9228	9413	0

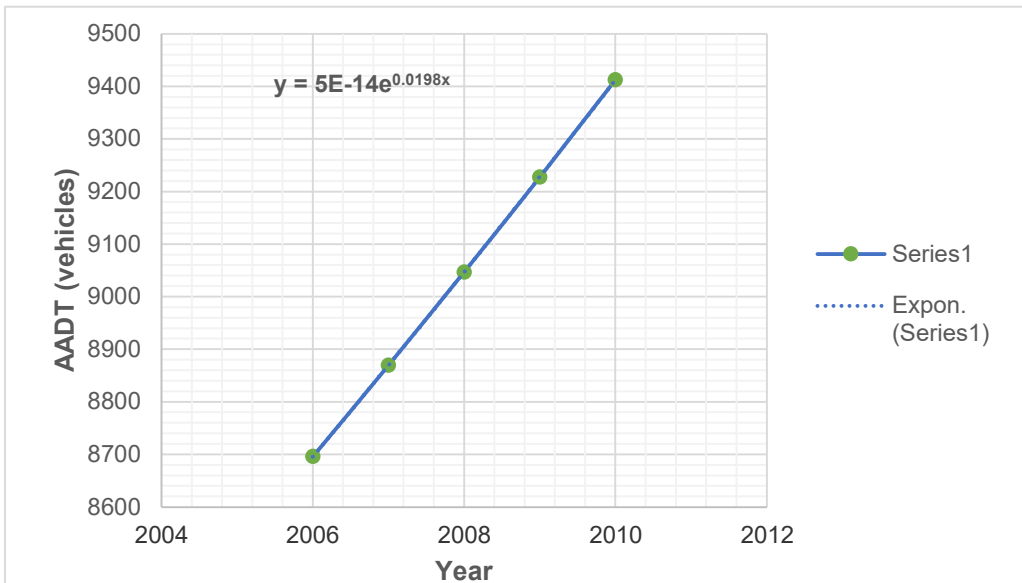

APPENDIX D

Future Background Level of Service

Queues

3: Yonge St & Eagle St W/Eagle St

12/23/2020

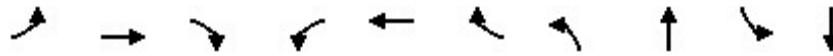

Lane Group	EBL	EBT	EBR	WBL	WBT	WBR	NBL	NBT	SBL	SBT
Lane Group Flow (vph)	55	287	155	141	338	85	238	865	151	879
Act Effect Green (s)	26.2	26.2	26.2	45.3	44.8	44.8	21.7	39.4	18.0	35.7
Actuated g/C Ratio	0.23	0.23	0.23	0.39	0.38	0.38	0.19	0.34	0.15	0.31
v/c Ratio	0.23	0.66	0.31	0.39	0.45	0.12	0.69	0.70	0.53	0.79
Control Delay	40.3	49.3	7.1	27.1	29.0	4.3	57.3	38.4	54.0	44.0
Queue Delay	0.0	0.0	0.0	0.0	0.0	0.0	0.0	0.0	0.0	0.0
Total Delay	40.3	49.3	7.1	27.1	29.0	4.3	57.3	38.4	54.0	44.0
LOS	D	D	A	C	C	A	E	D	D	D
Approach Delay		35.1			24.8			42.5		45.5
Approach LOS		D			C			D		D
Queue Length 50th (m)	10.8	62.4	0.0	21.9	58.9	0.0	52.5	90.1	33.5	99.7
Queue Length 95th (m)	22.4	92.0	15.5	36.2	85.0	8.4	86.8	136.3	56.6	#142.5
Internal Link Dist (m)		212.4			147.9			184.0		260.3
Turn Bay Length (m)	171.0		52.0	120.0		55.0	85.0		110.0	
Base Capacity (vph)	371	666	670	378	1004	898	400	1229	400	1159
Starvation Cap Reductn	0	0	0	0	0	0	0	0	0	0
Spillback Cap Reductn	0	0	0	0	0	0	0	0	0	0
Storage Cap Reductn	0	0	0	0	0	0	0	0	0	0
Reduced v/c Ratio	0.15	0.43	0.23	0.37	0.34	0.09	0.59	0.70	0.38	0.76

Intersection Summary

Cycle Length: 135

Actuated Cycle Length: 116.4

Control Type: Semi Act-Uncoord

Maximum v/c Ratio: 0.79

Intersection Signal Delay: 39.2

Intersection LOS: D

Intersection Capacity Utilization 77.5%

ICU Level of Service D

Analysis Period (min) 15

95th percentile volume exceeds capacity, queue may be longer.

Queue shown is maximum after two cycles.

HCM Signalized Intersection Capacity Analysis

3: Yonge St & Eagle St W/Eagle St

12/23/2020



Movement	EBL	EBT	EBR	WBL	WBT	WBR	NBL	NBT	NBR	SBL	SBT	SBR
Lane Configurations												
Traffic Volume (vph)	51	264	143	130	311	78	219	667	129	139	733	75
Future Volume (vph)	51	264	143	130	311	78	219	667	129	139	733	75
Ideal Flow (vphpl)	2000	2000	2000	2000	2000	2000	2000	2000	2000	2000	2000	2000
Total Lost time (s)	5.5	5.5	5.5	5.0	5.5	5.5	3.0	5.5		3.0	5.5	
Lane Util. Factor	1.00	1.00	1.00	1.00	1.00	1.00	1.00	0.95		1.00	0.95	
Frt	1.00	1.00	0.85	1.00	1.00	0.85	1.00	0.98		1.00	0.99	
Flt Protected	0.95	1.00	1.00	0.95	1.00	1.00	0.95	1.00		0.95	1.00	
Satd. Flow (prot)	1842	1939	1648	1842	1939	1648	1842	3595		1842	3633	
Flt Permitted	0.56	1.00	1.00	0.28	1.00	1.00	0.95	1.00		0.95	1.00	
Satd. Flow (perm)	1081	1939	1648	533	1939	1648	1842	3595		1842	3633	
Peak-hour factor, PHF	0.92	0.92	0.92	0.92	0.92	0.92	0.92	0.92	0.92	0.92	0.92	0.92
Adj. Flow (vph)	55	287	155	141	338	85	238	725	140	151	797	82
RTOR Reduction (vph)	0	0	120	0	0	52	0	11	0	0	6	0
Lane Group Flow (vph)	55	287	35	141	338	33	238	854	0	151	873	0
Turn Type	Perm	NA	Perm	pm+pt	NA	Perm	Prot	NA		Prot	NA	
Protected Phases		4		3	8		5	2		1	6	
Permitted Phases	4		4	8		8						
Actuated Green, G (s)	23.3	23.3	23.3	41.8	41.8	41.8	18.7	36.5		14.9	32.7	
Effective Green, g (s)	26.3	26.3	26.3	44.8	44.8	44.8	21.7	39.5		17.9	35.7	
Actuated g/C Ratio	0.23	0.23	0.23	0.39	0.39	0.39	0.19	0.34		0.15	0.31	
Clearance Time (s)	8.5	8.5	8.5	8.0	8.5	8.5	6.0	8.5		6.0	8.5	
Vehicle Extension (s)	3.0	3.0	3.0	3.0	3.0	3.0	3.0	3.0		3.0	3.0	
Lane Grp Cap (vph)	244	438	372	357	747	635	343	1222		283	1116	
v/s Ratio Prot		c0.15		0.05	c0.17		c0.13	0.24		0.08	c0.24	
v/s Ratio Perm	0.05		0.02	0.11		0.02						
v/c Ratio	0.23	0.66	0.09	0.39	0.45	0.05	0.69	0.70		0.53	0.78	
Uniform Delay, d1	36.6	40.8	35.5	25.1	26.6	22.4	44.1	33.2		45.3	36.7	
Progression Factor	1.00	1.00	1.00	1.00	1.00	1.00	1.00	1.00		1.00	1.00	
Incremental Delay, d2	0.5	3.5	0.1	0.7	0.4	0.0	6.0	1.8		1.9	3.7	
Delay (s)	37.1	44.3	35.6	25.8	27.0	22.4	50.1	35.0		47.2	40.4	
Level of Service	D	D	D	C	C	C	D	C		D	D	
Approach Delay (s)		40.8			26.0			38.2			41.4	
Approach LOS		D			C			D			D	

Intersection Summary

HCM 2000 Control Delay	37.5	HCM 2000 Level of Service	D
HCM 2000 Volume to Capacity ratio	0.69		
Actuated Cycle Length (s)	116.2	Sum of lost time (s)	19.0
Intersection Capacity Utilization	77.5%	ICU Level of Service	D
Analysis Period (min)	15		

c Critical Lane Group

HCM Unsignalized Intersection Capacity Analysis

6: Dixon Blvd & Eagle St

12/23/2020



Movement	EBT	EBR	WBL	WBT	NBL	NBR
Lane Configurations	→			←	↔	↔
Traffic Volume (veh/h)	560	16	11	541	26	24
Future Volume (Veh/h)	560	16	11	541	26	24
Sign Control	Free			Free	Stop	
Grade	0%			0%	0%	
Peak Hour Factor	0.92	0.92	0.92	0.92	0.92	0.92
Hourly flow rate (vph)	609	17	12	588	28	26
Pedestrians						
Lane Width (m)						
Walking Speed (m/s)						
Percent Blockage						
Right turn flare (veh)						
Median type	None			None		
Median storage veh						
Upstream signal (m)	172					
pX, platoon unblocked			0.86		0.86	0.86
vC, conflicting volume			626		1230	618
vC1, stage 1 conf vol						
vC2, stage 2 conf vol						
vCu, unblocked vol			487		1186	477
tC, single (s)			4.1		6.4	6.2
tC, 2 stage (s)						
tF (s)			2.2		3.5	3.3
p0 queue free %			99		84	95
cM capacity (veh/h)			928		177	507
Direction, Lane #	EB 1	WB 1	NB 1			
Volume Total	626	600	54			
Volume Left	0	12	28			
Volume Right	17	0	26			
cSH	1700	928	258			
Volume to Capacity	0.37	0.01	0.21			
Queue Length 95th (m)	0.0	0.3	5.9			
Control Delay (s)	0.0	0.4	22.6			
Lane LOS			A			C
Approach Delay (s)	0.0	0.4	22.6			
Approach LOS			C			
Intersection Summary						
Average Delay			1.1			
Intersection Capacity Utilization			45.4%	ICU Level of Service	A	
Analysis Period (min)			15			

HCM Unsignalized Intersection Capacity Analysis

8: Donlin Ave & Eagle St

12/23/2020



Movement	EBT	EBR	WBL	WBT	NBL	NBR
Lane Configurations	→			←	←	↘
Traffic Volume (veh/h)	602	3	0	553	1	2
Future Volume (Veh/h)	602	3	0	553	1	2
Sign Control	Free			Free	Stop	
Grade	0%			0%	0%	
Peak Hour Factor	0.92	0.92	0.92	0.92	0.92	0.92
Hourly flow rate (vph)	654	3	0	601	1	2
Pedestrians						
Lane Width (m)						
Walking Speed (m/s)						
Percent Blockage						
Right turn flare (veh)						
Median type	None			None		
Median storage (veh)						
Upstream signal (m)	287					
pX, platoon unblocked					0.89	
vC, conflicting volume	657			1256	656	
vC1, stage 1 conf vol						
vC2, stage 2 conf vol						
vCu, unblocked vol	657			1226	656	
tC, single (s)	4.1			6.4	6.2	
tC, 2 stage (s)						
tF (s)	2.2			3.5	3.3	
p0 queue free %	100			99	100	
cM capacity (veh/h)	931			175	466	
Direction, Lane #	EB 1	WB 1	NB 1			
Volume Total	657	601	3			
Volume Left	0	0	1			
Volume Right	3	0	2			
cSH	1700	931	300			
Volume to Capacity	0.39	0.00	0.01			
Queue Length 95th (m)	0.0	0.0	0.2			
Control Delay (s)	0.0	0.0	17.1			
Lane LOS				C		
Approach Delay (s)	0.0	0.0	17.1			
Approach LOS				C		
Intersection Summary						
Average Delay	0.0					
Intersection Capacity Utilization	40.3%			ICU Level of Service	A	
Analysis Period (min)	15					

Queues

10: Sanford St/Carol Ave & Eagle St

12/23/2020

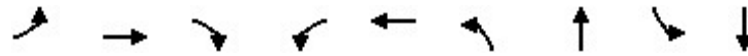

Lane Group	EBL	EBT	EBR	WBL	WBT	NBL	NBT	SBL	SBT
Lane Group Flow (vph)	17	632	36	75	545	51	203	26	100
Act Effect Green (s)	33.6	33.6	33.6	33.6	33.6	13.7	13.7	13.7	13.7
Actuated g/C Ratio	0.62	0.62	0.62	0.62	0.62	0.25	0.25	0.25	0.25
v/c Ratio	0.04	0.53	0.03	0.19	0.45	0.15	0.38	0.10	0.20
Control Delay	4.6	8.0	1.4	6.2	7.2	17.3	9.2	17.0	11.2
Queue Delay	0.0	0.0	0.0	0.0	0.0	0.0	0.0	0.0	0.0
Total Delay	4.6	8.0	1.4	6.2	7.2	17.3	9.2	17.0	11.2
LOS	A	A	A	A	A	B	A	B	B
Approach Delay		7.6			7.0		10.8		12.4
Approach LOS		A			A		B		B
Queue Length 50th (m)	0.5	27.8	0.0	2.5	22.4	3.8	5.3	1.9	3.9
Queue Length 95th (m)	2.6	57.3	2.0	8.4	46.3	11.1	19.1	7.0	13.5
Internal Link Dist (m)		263.5			65.3		306.7		229.9
Turn Bay Length (m)	86.0		32.0			50.0		58.0	
Base Capacity (vph)	505	1288	1111	430	1285	545	788	418	759
Starvation Cap Reductn	0	0	0	0	0	0	0	0	0
Spillback Cap Reductn	0	0	0	0	0	0	0	0	0
Storage Cap Reductn	0	0	0	0	0	0	0	0	0
Reduced v/c Ratio	0.03	0.49	0.03	0.17	0.42	0.09	0.26	0.06	0.13

Intersection Summary

Cycle Length: 65

Actuated Cycle Length: 54.3

Control Type: Semi Act-Uncoord

Maximum v/c Ratio: 0.53

Intersection Signal Delay: 8.2

Intersection LOS: A

Intersection Capacity Utilization 80.1%

ICU Level of Service D

Analysis Period (min) 15

HCM Signalized Intersection Capacity Analysis

10: Sanford St/Carol Ave & Eagle St

12/23/2020



Movement	EBL	EBT	EBR	WBL	WBT	WBR	NBL	NBT	NBR	SBL	SBT	SBR
Lane Configurations												
Traffic Volume (vph)	16	581	33	69	494	7	47	65	121	24	49	43
Future Volume (vph)	16	581	33	69	494	7	47	65	121	24	49	43
Ideal Flow (vphpl)	2000	2000	2000	2000	2000	2000	2000	2000	2000	2000	2000	2000
Total Lost time (s)	4.0	4.0	4.0	4.0	4.0		3.0	3.0		3.0	3.0	
Lane Util. Factor	1.00	1.00	1.00	1.00	1.00		1.00	1.00		1.00	1.00	
Frt	1.00	1.00	0.85	1.00	1.00		1.00	0.90		1.00	0.93	
Flt Protected	0.95	1.00	1.00	0.95	1.00		0.95	1.00		0.95	1.00	
Satd. Flow (prot)	1842	1939	1648	1842	1935		1842	1750		1842	1802	
Flt Permitted	0.39	1.00	1.00	0.33	1.00		0.69	1.00		0.53	1.00	
Satd. Flow (perm)	761	1939	1648	647	1935		1342	1750		1030	1802	
Peak-hour factor, PHF	0.92	0.92	0.92	0.92	0.92	0.92	0.92	0.92	0.92	0.92	0.92	0.92
Adj. Flow (vph)	17	632	36	75	537	8	51	71	132	26	53	47
RTOR Reduction (vph)	0	0	14	0	1	0	0	99	0	0	35	0
Lane Group Flow (vph)	17	632	22	75	544	0	51	104	0	26	65	0
Turn Type	Perm	NA	Perm	Perm	NA		Perm	NA		Perm	NA	
Protected Phases		4			8			2			6	
Permitted Phases	4		4	8			2			6		
Actuated Green, G (s)	30.6	30.6	30.6	30.6	30.6		10.7	10.7		10.7	10.7	
Effective Green, g (s)	33.6	33.6	33.6	33.6	33.6		13.7	13.7		13.7	13.7	
Actuated g/C Ratio	0.62	0.62	0.62	0.62	0.62		0.25	0.25		0.25	0.25	
Clearance Time (s)	7.0	7.0	7.0	7.0	7.0		6.0	6.0		6.0	6.0	
Vehicle Extension (s)	3.0	3.0	3.0	3.0	3.0		3.0	3.0		3.0	3.0	
Lane Grp Cap (vph)	470	1199	1019	400	1197		338	441		259	454	
v/s Ratio Prot		c0.33			0.28			c0.06			0.04	
v/s Ratio Perm	0.02		0.01	0.12			0.04			0.03		
v/c Ratio	0.04	0.53	0.02	0.19	0.45		0.15	0.24		0.10	0.14	
Uniform Delay, d1	4.0	5.9	4.0	4.5	5.5		15.8	16.1		15.6	15.7	
Progression Factor	1.00	1.00	1.00	1.00	1.00		1.00	1.00		1.00	1.00	
Incremental Delay, d2	0.0	0.4	0.0	0.2	0.3		0.2	0.3		0.2	0.1	
Delay (s)	4.1	6.3	4.0	4.7	5.8		16.0	16.4		15.7	15.9	
Level of Service	A	A	A	A	A		B	B		B	B	
Approach Delay (s)		6.1			5.6			16.3			15.9	
Approach LOS		A			A			B			B	

Intersection Summary

HCM 2000 Control Delay	8.2	HCM 2000 Level of Service	A
HCM 2000 Volume to Capacity ratio	0.44		
Actuated Cycle Length (s)	54.3	Sum of lost time (s)	7.0
Intersection Capacity Utilization	80.1%	ICU Level of Service	D
Analysis Period (min)	15		

c Critical Lane Group

Queues

3: Yonge St & Eagle St W/Eagle St

12/23/2020

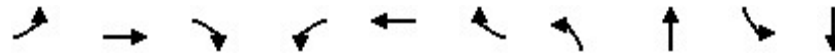

Lane Group	EBL	EBT	EBR	WBL	WBT	WBR	NBL	NBT	SBL	SBT
Lane Group Flow (vph)	65	313	237	166	365	120	153	1182	148	876
Act Effct Green (s)	26.4	29.4	26.4	44.1	43.6	43.6	17.5	46.0	17.3	45.9
Actuated g/C Ratio	0.21	0.23	0.21	0.35	0.35	0.35	0.14	0.37	0.14	0.37
v/c Ratio	0.29	0.69	0.46	0.66	0.54	0.19	0.60	0.88	0.58	0.65
Control Delay	46.1	52.5	11.4	44.2	36.6	6.5	62.9	46.7	62.4	36.7
Queue Delay	0.0	0.0	0.0	0.0	0.0	0.0	0.0	0.0	0.0	0.0
Total Delay	46.1	52.5	11.4	44.2	36.6	6.5	62.9	46.7	62.4	36.7
LOS	D	D	B	D	D	A	E	D	E	D
Approach Delay		36.0			33.0			48.6		40.4
Approach LOS		D			C			D		D
Queue Length 50th (m)	14.1	73.4	6.2	30.3	75.1	1.2	36.6	143.4	35.4	95.0
Queue Length 95th (m)	27.6	105.4	28.1	48.0	106.1	13.7	63.3	#208.3	61.4	132.3
Internal Link Dist (m)		212.4			146.8			184.0		260.3
Turn Bay Length (m)	171.0		52.0	120.0		55.0	85.0		110.0	
Base Capacity (vph)	311	620	632	250	839	777	298	1426	298	1439
Starvation Cap Reductn	0	0	0	0	0	0	0	0	0	0
Spillback Cap Reductn	0	0	0	0	0	0	0	0	0	0
Storage Cap Reductn	0	0	0	0	0	0	0	0	0	0
Reduced v/c Ratio	0.21	0.50	0.38	0.66	0.44	0.15	0.51	0.83	0.50	0.61

Intersection Summary

Cycle Length: 140

Actuated Cycle Length: 125.2

Control Type: Semi Act-Uncoord

Maximum v/c Ratio: 0.88

Intersection Signal Delay: 41.3

Intersection LOS: D

Intersection Capacity Utilization 84.3%

ICU Level of Service E

Analysis Period (min) 15

95th percentile volume exceeds capacity, queue may be longer.

Queue shown is maximum after two cycles.

HCM Signalized Intersection Capacity Analysis

3: Yonge St & Eagle St W/Eagle St

12/23/2020



Movement	EBL	EBT	EBR	WBL	WBT	WBR	NBL	NBT	NBR	SBL	SBT	SBR
Lane Configurations												
Traffic Volume (vph)	60	288	218	153	336	110	141	953	134	136	775	31
Future Volume (vph)	60	288	218	153	336	110	141	953	134	136	775	31
Ideal Flow (vphpl)	2000	2000	2000	2000	2000	2000	2000	2000	2000	2000	2000	2000
Total Lost time (s)	8.5	5.5	8.5	7.0	7.5	7.5	3.0	7.5		3.0	7.5	
Lane Util. Factor	1.00	1.00	1.00	1.00	1.00	1.00	1.00	0.95		1.00	0.95	
Frt	1.00	1.00	0.85	1.00	1.00	0.85	1.00	0.98		1.00	0.99	
Flt Protected	0.95	1.00	1.00	0.95	1.00	1.00	0.95	1.00		0.95	1.00	
Satd. Flow (prot)	1842	1939	1648	1842	1939	1648	1842	3616		1842	3663	
Flt Permitted	0.54	1.00	1.00	0.21	1.00	1.00	0.95	1.00		0.95	1.00	
Satd. Flow (perm)	1054	1939	1648	414	1939	1648	1842	3616		1842	3663	
Peak-hour factor, PHF	0.92	0.92	0.92	0.92	0.92	0.92	0.92	0.92	0.92	0.92	0.92	0.92
Adj. Flow (vph)	65	313	237	166	365	120	153	1036	146	148	842	34
RTOR Reduction (vph)	0	0	163	0	0	74	0	8	0	0	2	0
Lane Group Flow (vph)	65	313	74	166	365	46	153	1174	0	148	874	0
Turn Type	Perm	NA	Perm	pm+pt	NA	Perm	Prot	NA		Prot	NA	
Protected Phases		4		3	8		5	2		1	6	
Permitted Phases	4		4	8		8						
Actuated Green, G (s)	26.5	26.5	26.5	42.6	42.6	42.6	14.4	45.0		14.3	44.9	
Effective Green, g (s)	26.5	29.5	26.5	43.6	43.6	43.6	17.4	46.0		17.3	45.9	
Actuated g/C Ratio	0.21	0.24	0.21	0.35	0.35	0.35	0.14	0.37		0.14	0.37	
Clearance Time (s)	8.5	8.5	8.5	8.0	8.5	8.5	6.0	8.5		6.0	8.5	
Vehicle Extension (s)	3.0	3.0	3.0	3.0	3.0	3.0	3.0	3.0		3.0	3.0	
Lane Grp Cap (vph)	223	457	349	248	676	575	256	1331		255	1346	
v/s Ratio Prot		c0.16		0.05	c0.19		c0.08	c0.32		0.08	0.24	
v/s Ratio Perm	0.06		0.04	0.18		0.03						
v/c Ratio	0.29	0.68	0.21	0.67	0.54	0.08	0.60	0.88		0.58	0.65	
Uniform Delay, d1	41.3	43.5	40.6	31.3	32.6	27.2	50.5	36.9		50.4	32.8	
Progression Factor	1.00	1.00	1.00	1.00	1.00	1.00	1.00	1.00		1.00	1.00	
Incremental Delay, d2	0.7	4.2	0.3	6.7	0.8	0.1	3.7	7.2		3.3	1.1	
Delay (s)	42.0	47.7	40.9	38.0	33.4	27.3	54.2	44.1		53.7	33.9	
Level of Service	D	D	D	D	C	C	D	D		D	C	
Approach Delay (s)		44.5			33.5			45.3			36.8	
Approach LOS		D			C			D			D	

Intersection Summary

HCM 2000 Control Delay	40.6	HCM 2000 Level of Service	D
HCM 2000 Volume to Capacity ratio	0.77		
Actuated Cycle Length (s)	124.9	Sum of lost time (s)	23.0
Intersection Capacity Utilization	84.3%	ICU Level of Service	E
Analysis Period (min)	15		

c Critical Lane Group

HCM Unsignalized Intersection Capacity Analysis

6: Dixon Blvd & Eagle St

12/23/2020



Movement	EBT	EBR	WBL	WBT	NBL	NBR
Lane Configurations	→	↘	↙	←	↘	↙
Traffic Volume (veh/h)	531	41	23	626	20	21
Future Volume (Veh/h)	531	41	23	626	20	21
Sign Control	Free			Free	Stop	
Grade	0%			0%	0%	
Peak Hour Factor	0.92	0.92	0.92	0.92	0.92	0.92
Hourly flow rate (vph)	577	45	25	680	22	23
Pedestrians						
Lane Width (m)						
Walking Speed (m/s)						
Percent Blockage						
Right turn flare (veh)						
Median type	None			None		
Median storage veh						
Upstream signal (m)	171					
pX, platoon unblocked			0.85		0.85	0.85
vC, conflicting volume			622		1330	600
vC1, stage 1 conf vol						
vC2, stage 2 conf vol						
vCu, unblocked vol			466		1299	439
tC, single (s)			4.1		6.4	6.2
tC, 2 stage (s)						
tF (s)			2.2		3.5	3.3
p0 queue free %			97		85	96
cM capacity (veh/h)			930		147	524
Direction, Lane #	EB 1	WB 1	NB 1			
Volume Total	622	705	45			
Volume Left	0	25	22			
Volume Right	45	0	23			
cSH	1700	930	233			
Volume to Capacity	0.37	0.03	0.19			
Queue Length 95th (m)	0.0	0.6	5.3			
Control Delay (s)	0.0	0.7	24.1			
Lane LOS		A	C			
Approach Delay (s)	0.0	0.7	24.1			
Approach LOS			C			
Intersection Summary						
Average Delay			1.2			
Intersection Capacity Utilization			59.0%	ICU Level of Service		B
Analysis Period (min)			15			

HCM Unsignalized Intersection Capacity Analysis

8: Donlin Ave & Eagle St

12/23/2020

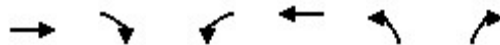

Movement	EBT	EBR	WBL	WBT	NBL	NBR
Lane Configurations						
Traffic Volume (veh/h)	641	3	4	652	0	51
Future Volume (Veh/h)	641	3	4	652	0	51
Sign Control	Free			Free	Stop	
Grade	0%			0%	0%	
Peak Hour Factor	0.92	0.92	0.92	0.92	0.92	0.92
Hourly flow rate (vph)	697	3	4	709	0	55
Pedestrians						
Lane Width (m)						
Walking Speed (m/s)						
Percent Blockage						
Right turn flare (veh)						
Median type	None			None		
Median storage veh						
Upstream signal (m)	230					
pX, platoon unblocked					0.75	
vC, conflicting volume			700	1416	698	
vC1, stage 1 conf vol						
vC2, stage 2 conf vol						
vCu, unblocked vol			700	1387	698	
tC, single (s)			4.1	6.4	6.2	
tC, 2 stage (s)						
tF (s)			2.2	3.5	3.3	
p0 queue free %			100	100	88	
cM capacity (veh/h)			897	117	440	
Direction, Lane #	EB 1	WB 1	NB 1			
Volume Total	700	713	55			
Volume Left	0	4	0			
Volume Right	3	0	55			
cSH	1700	897	440			
Volume to Capacity	0.41	0.00	0.12			
Queue Length 95th (m)	0.0	0.1	3.2			
Control Delay (s)	0.0	0.1	14.3			
Lane LOS			A	B		
Approach Delay (s)	0.0	0.1	14.3			
Approach LOS			B			
Intersection Summary						
Average Delay			0.6			
Intersection Capacity Utilization			45.6%	ICU Level of Service	A	
Analysis Period (min)			15			

Queues

10: sanford St/Carol Ave & Eagle St

12/23/2020

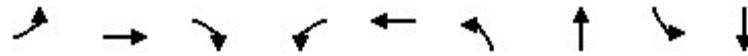

Lane Group	EBL	EBT	EBR	WBL	WBT	NBL	NBT	SBL	SBT
Lane Group Flow (vph)	36	622	71	112	678	68	192	43	137
Act Effect Green (s)	30.6	30.6	30.6	30.6	30.6	11.3	11.3	11.3	11.3
Actuated g/C Ratio	0.56	0.56	0.56	0.56	0.56	0.21	0.21	0.21	0.21
v/c Ratio	0.11	0.58	0.07	0.30	0.63	0.26	0.46	0.17	0.34
Control Delay	7.4	10.9	2.4	9.7	11.9	21.1	18.1	19.9	18.9
Queue Delay	0.0	0.0	0.0	0.0	0.0	0.0	0.0	0.0	0.0
Total Delay	7.4	10.9	2.4	9.7	11.9	21.1	18.1	19.9	18.9
LOS	A	B	A	A	B	C	B	B	B
Approach Delay		9.9			11.6		18.9		19.1
Approach LOS		A			B		B		B
Queue Length 50th (m)	1.4	32.9	0.2	4.8	37.3	5.6	12.0	3.5	10.0
Queue Length 95th (m)	5.7	70.3	4.6	15.5	80.0	14.9	28.0	10.5	23.1
Internal Link Dist (m)		206.0			73.5		168.7		142.5
Turn Bay Length (m)	83.0		32.0			55.0		58.0	
Base Capacity (vph)	355	1168	1019	405	1164	449	666	428	665
Starvation Cap Reductn	0	0	0	0	0	0	0	0	0
Spillback Cap Reductn	0	0	0	0	0	0	0	0	0
Storage Cap Reductn	0	0	0	0	0	0	0	0	0
Reduced v/c Ratio	0.10	0.53	0.07	0.28	0.58	0.15	0.29	0.10	0.21

Intersection Summary

Cycle Length: 65

Actuated Cycle Length: 54.9

Control Type: Semi Act-Uncoord

Maximum v/c Ratio: 0.63

Intersection Signal Delay: 12.6

Intersection LOS: B

Intersection Capacity Utilization 95.7%

ICU Level of Service F

Analysis Period (min) 15

HCM Signalized Intersection Capacity Analysis

10: sanford St/Carol Ave & Eagle St

12/23/2020



Movement	EBL	EBT	EBR	WBL	WBT	WBR	NBL	NBT	NBR	SBL	SBT	SBR
Lane Configurations												
Traffic Volume (vph)	33	572	65	103	605	18	63	107	70	40	102	24
Future Volume (vph)	33	572	65	103	605	18	63	107	70	40	102	24
Ideal Flow (vphpl)	2000	2000	2000	2000	2000	2000	2000	2000	2000	2000	2000	2000
Total Lost time (s)	7.0	7.0	7.0	7.0	7.0		6.0	6.0		6.0	6.0	
Lane Util. Factor	1.00	1.00	1.00	1.00	1.00		1.00	1.00		1.00	1.00	
Frt	1.00	1.00	0.85	1.00	1.00		1.00	0.94		1.00	0.97	
Flt Protected	0.95	1.00	1.00	0.95	1.00		0.95	1.00		0.95	1.00	
Satd. Flow (prot)	1842	1939	1648	1842	1930		1842	1824		1842	1884	
Flt Permitted	0.30	1.00	1.00	0.35	1.00		0.67	1.00		0.64	1.00	
Satd. Flow (perm)	591	1939	1648	673	1930		1298	1824		1235	1884	
Peak-hour factor, PHF	0.92	0.92	0.92	0.92	0.92	0.92	0.92	0.92	0.92	0.92	0.92	0.92
Adj. Flow (vph)	36	622	71	112	658	20	68	116	76	43	111	26
RTOR Reduction (vph)	0	0	30	0	1	0	0	41	0	0	14	0
Lane Group Flow (vph)	36	622	41	112	677	0	68	151	0	43	123	0
Turn Type	Perm	NA	Perm	Perm	NA		Perm	NA		Perm	NA	
Protected Phases		4			8			2			6	
Permitted Phases	4		4	8			2			6		
Actuated Green, G (s)	30.6	30.6	30.6	30.6	30.6		11.3	11.3		11.3	11.3	
Effective Green, g (s)	30.6	30.6	30.6	30.6	30.6		11.3	11.3		11.3	11.3	
Actuated g/C Ratio	0.56	0.56	0.56	0.56	0.56		0.21	0.21		0.21	0.21	
Clearance Time (s)	7.0	7.0	7.0	7.0	7.0		6.0	6.0		6.0	6.0	
Vehicle Extension (s)	3.0	3.0	3.0	3.0	3.0		3.0	3.0		3.0	3.0	
Lane Grp Cap (vph)	329	1080	918	375	1075		267	375		254	387	
v/s Ratio Prot		0.32			c0.35			c0.08			0.07	
v/s Ratio Perm	0.06		0.03	0.17			0.05			0.03		
v/c Ratio	0.11	0.58	0.05	0.30	0.63		0.25	0.40		0.17	0.32	
Uniform Delay, d1	5.7	7.9	5.5	6.5	8.3		18.3	18.9		17.9	18.5	
Progression Factor	1.00	1.00	1.00	1.00	1.00		1.00	1.00		1.00	1.00	
Incremental Delay, d2	0.1	0.7	0.0	0.4	1.2		0.5	0.7		0.3	0.5	
Delay (s)	5.9	8.7	5.5	6.9	9.4		18.8	19.6		18.3	19.0	
Level of Service	A	A	A	A	A		B	B		B	B	
Approach Delay (s)		8.2			9.1			19.4			18.8	
Approach LOS		A			A			B			B	

Intersection Summary			
HCM 2000 Control Delay	11.0	HCM 2000 Level of Service	B
HCM 2000 Volume to Capacity ratio	0.57		
Actuated Cycle Length (s)	54.9	Sum of lost time (s)	13.0
Intersection Capacity Utilization	95.7%	ICU Level of Service	F
Analysis Period (min)	15		

c Critical Lane Group

APPENDIX E

Future Total Level of Service

Queues

3: Yonge St & Eagle St W/Eagle St

12/23/2020

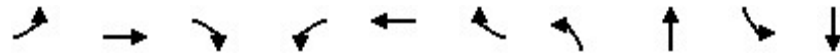

Lane Group	EBL	EBT	EBR	WBL	WBT	WBR	NBL	NBT	SBL	SBT
Lane Group Flow (vph)	55	287	155	149	338	93	238	867	152	879
Act Effct Green (s)	26.2	26.2	26.2	45.5	45.0	45.0	21.7	39.4	18.0	35.7
Actuated g/C Ratio	0.22	0.22	0.22	0.39	0.39	0.39	0.19	0.34	0.15	0.31
v/c Ratio	0.23	0.66	0.32	0.41	0.45	0.13	0.70	0.71	0.54	0.79
Control Delay	40.3	49.4	7.1	27.4	29.0	5.0	57.5	38.6	54.1	44.1
Queue Delay	0.0	0.0	0.0	0.0	0.0	0.0	0.0	0.0	0.0	0.0
Total Delay	40.3	49.4	7.1	27.4	29.0	5.0	57.5	38.6	54.1	44.1
LOS	D	D	A	C	C	A	E	D	D	D
Approach Delay		35.2			24.7			42.7		45.6
Approach LOS		D			C			D		D
Queue Length 50th (m)	10.8	62.7	0.0	23.2	58.9	0.0	52.7	91.0	33.9	100.2
Queue Length 95th (m)	22.4	92.0	15.5	38.1	85.0	9.9	86.8	136.6	56.8	#142.5
Internal Link Dist (m)		212.4			147.9			184.0		260.3
Turn Bay Length (m)	171.0		52.0	120.0		55.0	85.0		110.0	
Base Capacity (vph)	370	665	669	378	1002	897	400	1224	400	1157
Starvation Cap Reductn	0	0	0	0	0	0	0	0	0	0
Spillback Cap Reductn	0	0	0	0	0	0	0	0	0	0
Storage Cap Reductn	0	0	0	0	0	0	0	0	0	0
Reduced v/c Ratio	0.15	0.43	0.23	0.39	0.34	0.10	0.59	0.71	0.38	0.76

Intersection Summary

Cycle Length: 135

Actuated Cycle Length: 116.6

Control Type: Semi Act-Uncoord

Maximum v/c Ratio: 0.79

Intersection Signal Delay: 39.2

Intersection LOS: D

Intersection Capacity Utilization 77.5%

ICU Level of Service D

Analysis Period (min) 15

95th percentile volume exceeds capacity, queue may be longer.

Queue shown is maximum after two cycles.

HCM Signalized Intersection Capacity Analysis

3: Yonge St & Eagle St W/Eagle St

12/23/2020



Movement	EBL	EBT	EBR	WBL	WBT	WBR	NBL	NBT	NBR	SBL	SBT	SBR
Lane Configurations												
Traffic Volume (vph)	51	264	143	137	311	86	219	667	131	140	733	75
Future Volume (vph)	51	264	143	137	311	86	219	667	131	140	733	75
Ideal Flow (vphpl)	2000	2000	2000	2000	2000	2000	2000	2000	2000	2000	2000	2000
Total Lost time (s)	5.5	5.5	5.5	5.0	5.5	5.5	3.0	5.5		3.0	5.5	
Lane Util. Factor	1.00	1.00	1.00	1.00	1.00	1.00	1.00	0.95		1.00	0.95	
Frt	1.00	1.00	0.85	1.00	1.00	0.85	1.00	0.98		1.00	0.99	
Flt Protected	0.95	1.00	1.00	0.95	1.00	1.00	0.95	1.00		0.95	1.00	
Satd. Flow (prot)	1842	1939	1648	1842	1939	1648	1842	3594		1842	3633	
Flt Permitted	0.56	1.00	1.00	0.27	1.00	1.00	0.95	1.00		0.95	1.00	
Satd. Flow (perm)	1081	1939	1648	532	1939	1648	1842	3594		1842	3633	
Peak-hour factor, PHF	0.92	0.92	0.92	0.92	0.92	0.92	0.92	0.92	0.92	0.92	0.92	0.92
Adj. Flow (vph)	55	287	155	149	338	93	238	725	142	152	797	82
RTOR Reduction (vph)	0	0	120	0	0	57	0	11	0	0	6	0
Lane Group Flow (vph)	55	287	35	149	338	36	238	856	0	152	873	0
Turn Type	Perm	NA	Perm	pm+pt	NA	Perm	Prot	NA		Prot	NA	
Protected Phases		4		3	8		5	2		1	6	
Permitted Phases	4		4	8		8						
Actuated Green, G (s)	23.3	23.3	23.3	42.0	42.0	42.0	18.7	36.4		15.0	32.7	
Effective Green, g (s)	26.3	26.3	26.3	45.0	45.0	45.0	21.7	39.4		18.0	35.7	
Actuated g/C Ratio	0.23	0.23	0.23	0.39	0.39	0.39	0.19	0.34		0.15	0.31	
Clearance Time (s)	8.5	8.5	8.5	8.0	8.5	8.5	6.0	8.5		6.0	8.5	
Vehicle Extension (s)	3.0	3.0	3.0	3.0	3.0	3.0	3.0	3.0		3.0	3.0	
Lane Grp Cap (vph)	244	438	372	359	749	637	343	1216		284	1114	
v/s Ratio Prot		c0.15		0.05	c0.17		c0.13	0.24		0.08	c0.24	
v/s Ratio Perm	0.05		0.02	0.11		0.02						
v/c Ratio	0.23	0.66	0.09	0.42	0.45	0.06	0.69	0.70		0.54	0.78	
Uniform Delay, d1	36.7	40.9	35.6	25.2	26.5	22.4	44.2	33.4		45.3	36.8	
Progression Factor	1.00	1.00	1.00	1.00	1.00	1.00	1.00	1.00		1.00	1.00	
Incremental Delay, d2	0.5	3.5	0.1	0.8	0.4	0.0	6.0	1.9		1.9	3.7	
Delay (s)	37.2	44.4	35.7	26.0	27.0	22.4	50.2	35.3		47.3	40.5	
Level of Service	D	D	D	C	C	C	D	D		D	D	
Approach Delay (s)		40.9			26.0			38.5			41.5	
Approach LOS		D			C			D			D	

Intersection Summary

HCM 2000 Control Delay	37.6	HCM 2000 Level of Service	D
HCM 2000 Volume to Capacity ratio	0.69		
Actuated Cycle Length (s)	116.4	Sum of lost time (s)	19.0
Intersection Capacity Utilization	77.5%	ICU Level of Service	D
Analysis Period (min)	15		

c Critical Lane Group

HCM Unsignalized Intersection Capacity Analysis

6: Dixon Blvd & Eagle St

12/23/2020



Movement	EBT	EBR	WBL	WBT	NBL	NBR
Lane Configurations	→			←	↔	↔
Traffic Volume (veh/h)	563	16	11	541	26	24
Future Volume (Veh/h)	563	16	11	541	26	24
Sign Control	Free			Free	Stop	
Grade	0%			0%	0%	
Peak Hour Factor	0.92	0.92	0.92	0.92	0.92	0.92
Hourly flow rate (vph)	612	17	12	588	28	26
Pedestrians						
Lane Width (m)						
Walking Speed (m/s)						
Percent Blockage						
Right turn flare (veh)						
Median type	None			None		
Median storage (veh)						
Upstream signal (m)	172					
pX, platoon unblocked			0.86		0.86	0.86
vC, conflicting volume			629		1232	620
vC1, stage 1 conf vol						
vC2, stage 2 conf vol						
vCu, unblocked vol			490		1190	480
tC, single (s)			4.1		6.4	6.2
tC, 2 stage (s)						
tF (s)			2.2		3.5	3.3
p0 queue free %			99		84	95
cM capacity (veh/h)			926		177	505
Direction, Lane #	EB 1	WB 1	NB 1			
Volume Total	629	600	54			
Volume Left	0	12	28			
Volume Right	17	0	26			
cSH	1700	926	257			
Volume to Capacity	0.37	0.01	0.21			
Queue Length 95th (m)	0.0	0.3	5.9			
Control Delay (s)	0.0	0.4	22.7			
Lane LOS		A	C			
Approach Delay (s)	0.0	0.4	22.7			
Approach LOS			C			
Intersection Summary						
Average Delay			1.1			
Intersection Capacity Utilization			45.4%	ICU Level of Service	A	
Analysis Period (min)			15			

HCM Unsignalized Intersection Capacity Analysis

8: Donlin Ave & Eagle St

12/23/2020



Movement	EBT	EBR	WBL	WBT	NBL	NBR
Lane Configurations	→	↘	↙	←	↘	↙
Traffic Volume (veh/h)	608	3	0	556	1	2
Future Volume (Veh/h)	608	3	0	556	1	2
Sign Control	Free			Free	Stop	
Grade	0%			0%	0%	
Peak Hour Factor	0.92	0.92	0.92	0.92	0.92	0.92
Hourly flow rate (vph)	661	3	0	604	1	2
Pedestrians						
Lane Width (m)						
Walking Speed (m/s)						
Percent Blockage						
Right turn flare (veh)						
Median type	None			None		
Median storage veh						
Upstream signal (m)	287					
pX, platoon unblocked					0.89	
vC, conflicting volume			664	1266		662
vC1, stage 1 conf vol						
vC2, stage 2 conf vol						
vCu, unblocked vol			664	1237	662	
tC, single (s)			4.1	6.4	6.2	
tC, 2 stage (s)						
tF (s)			2.2	3.5	3.3	
p0 queue free %			100	99	100	
cM capacity (veh/h)			925	172	462	
Direction, Lane #	EB 1	WB 1	NB 1			
Volume Total	664	604	3			
Volume Left	0	0	1			
Volume Right	3	0	2			
cSH	1700	925	296			
Volume to Capacity	0.39	0.00	0.01			
Queue Length 95th (m)	0.0	0.0	0.2			
Control Delay (s)	0.0	0.0	17.3			
Lane LOS			C			
Approach Delay (s)	0.0	0.0	17.3			
Approach LOS			C			
Intersection Summary						
Average Delay			0.0			
Intersection Capacity Utilization			40.6%	ICU Level of Service		A
Analysis Period (min)			15			

Queues

10: Sanford St/Carol Ave & Eagle St

12/23/2020

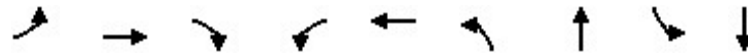

Lane Group	EBL	EBT	EBR	WBL	WBT	NBL	NBT	SBL	SBT
Lane Group Flow (vph)	17	638	36	75	548	51	203	26	100
Act Effect Green (s)	33.6	33.6	33.6	33.6	33.6	13.7	13.7	13.7	13.7
Actuated g/C Ratio	0.62	0.62	0.62	0.62	0.62	0.25	0.25	0.25	0.25
v/c Ratio	0.04	0.53	0.03	0.19	0.46	0.15	0.38	0.10	0.20
Control Delay	4.6	8.1	1.4	6.2	7.2	17.3	9.2	17.0	11.2
Queue Delay	0.0	0.0	0.0	0.0	0.0	0.0	0.0	0.0	0.0
Total Delay	4.6	8.1	1.4	6.2	7.2	17.3	9.2	17.0	11.2
LOS	A	A	A	A	A	B	A	B	B
Approach Delay		7.7			7.1		10.8		12.4
Approach LOS		A			A		B		B
Queue Length 50th (m)	0.5	28.2	0.0	2.5	22.6	3.8	5.3	1.9	3.9
Queue Length 95th (m)	2.6	58.2	2.0	8.4	46.7	11.1	19.1	7.0	13.5
Internal Link Dist (m)		263.5			65.3		306.7		229.9
Turn Bay Length (m)	86.0		32.0			50.0		58.0	
Base Capacity (vph)	502	1288	1111	424	1285	545	788	418	759
Starvation Cap Reductn	0	0	0	0	0	0	0	0	0
Spillback Cap Reductn	0	0	0	0	0	0	0	0	0
Storage Cap Reductn	0	0	0	0	0	0	0	0	0
Reduced v/c Ratio	0.03	0.50	0.03	0.18	0.43	0.09	0.26	0.06	0.13

Intersection Summary

Cycle Length: 65

Actuated Cycle Length: 54.3

Control Type: Semi Act-Uncoord

Maximum v/c Ratio: 0.53

Intersection Signal Delay: 8.3

Intersection LOS: A

Intersection Capacity Utilization 80.1%

ICU Level of Service D

Analysis Period (min) 15

HCM Signalized Intersection Capacity Analysis
 10: Sanford St/Carol Ave & Eagle St

12/23/2020

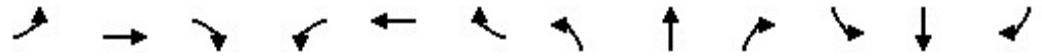

Movement	EBL	EBT	EBR	WBL	WBT	WBR	NBL	NBT	NBR	SBL	SBT	SBR
Lane Configurations												
Traffic Volume (vph)	16	587	33	69	497	7	47	65	121	24	49	43
Future Volume (vph)	16	587	33	69	497	7	47	65	121	24	49	43
Ideal Flow (vphpl)	2000	2000	2000	2000	2000	2000	2000	2000	2000	2000	2000	2000
Total Lost time (s)	4.0	4.0	4.0	4.0	4.0		3.0	3.0		3.0	3.0	
Lane Util. Factor	1.00	1.00	1.00	1.00	1.00		1.00	1.00		1.00	1.00	
Frt	1.00	1.00	0.85	1.00	1.00		1.00	0.90		1.00	0.93	
Flt Protected	0.95	1.00	1.00	0.95	1.00		0.95	1.00		0.95	1.00	
Satd. Flow (prot)	1842	1939	1648	1842	1935		1842	1750		1842	1802	
Flt Permitted	0.39	1.00	1.00	0.33	1.00		0.69	1.00		0.53	1.00	
Satd. Flow (perm)	757	1939	1648	640	1935		1342	1750		1030	1802	
Peak-hour factor, PHF	0.92	0.92	0.92	0.92	0.92	0.92	0.92	0.92	0.92	0.92	0.92	0.92
Adj. Flow (vph)	17	638	36	75	540	8	51	71	132	26	53	47
RTOR Reduction (vph)	0	0	14	0	1	0	0	99	0	0	35	0
Lane Group Flow (vph)	17	638	22	75	547	0	51	104	0	26	65	0
Turn Type	Perm	NA	Perm	Perm	NA		Perm	NA		Perm	NA	
Protected Phases		4			8			2			6	
Permitted Phases	4		4	8			2			6		
Actuated Green, G (s)	30.6	30.6	30.6	30.6	30.6		10.7	10.7		10.7	10.7	
Effective Green, g (s)	33.6	33.6	33.6	33.6	33.6		13.7	13.7		13.7	13.7	
Actuated g/C Ratio	0.62	0.62	0.62	0.62	0.62		0.25	0.25		0.25	0.25	
Clearance Time (s)	7.0	7.0	7.0	7.0	7.0		6.0	6.0		6.0	6.0	
Vehicle Extension (s)	3.0	3.0	3.0	3.0	3.0		3.0	3.0		3.0	3.0	
Lane Grp Cap (vph)	468	1199	1019	396	1197		338	441		259	454	
v/s Ratio Prot		c0.33			0.28			c0.06			0.04	
v/s Ratio Perm	0.02		0.01	0.12			0.04			0.03		
v/c Ratio	0.04	0.53	0.02	0.19	0.46		0.15	0.24		0.10	0.14	
Uniform Delay, d1	4.0	5.9	4.0	4.5	5.5		15.8	16.1		15.6	15.7	
Progression Factor	1.00	1.00	1.00	1.00	1.00		1.00	1.00		1.00	1.00	
Incremental Delay, d2	0.0	0.5	0.0	0.2	0.3		0.2	0.3		0.2	0.1	
Delay (s)	4.1	6.3	4.0	4.7	5.8		16.0	16.4		15.7	15.9	
Level of Service	A	A	A	A	A		B	B		B	B	
Approach Delay (s)		6.2			5.7			16.3			15.9	
Approach LOS		A			A			B			B	

Intersection Summary

HCM 2000 Control Delay	8.2	HCM 2000 Level of Service	A
HCM 2000 Volume to Capacity ratio	0.45		
Actuated Cycle Length (s)	54.3	Sum of lost time (s)	7.0
Intersection Capacity Utilization	80.1%	ICU Level of Service	D
Analysis Period (min)	15		

c Critical Lane Group

HCM Unsignalized Intersection Capacity Analysis

13: Eagle St & west access

12/23/2020

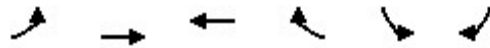

Movement	EBL	EBT	WBT	WBR	SBL	SBR
Lane Configurations		↖	↗		↘	
Traffic Volume (veh/h)	3	605	552	1	5	6
Future Volume (Veh/h)	3	605	552	1	5	6
Sign Control		Free	Free		Stop	
Grade		0%	0%		0%	
Peak Hour Factor	0.92	0.92	0.92	0.92	0.92	0.92
Hourly flow rate (vph)	3	658	600	1	5	7
Pedestrians						
Lane Width (m)						
Walking Speed (m/s)						
Percent Blockage						
Right turn flare (veh)						
Median type		None	None			
Median storage (veh)						
Upstream signal (m)		209				
pX, platoon unblocked					0.87	
vC, conflicting volume	601				1264	600
vC1, stage 1 conf vol						
vC2, stage 2 conf vol						
vCu, unblocked vol	601				1228	600
tC, single (s)	4.1				6.4	6.2
tC, 2 stage (s)						
tF (s)	2.2				3.5	3.3
p0 queue free %	100				97	99
cM capacity (veh/h)	976				170	501
Direction, Lane #	EB 1	WB 1	SB 1			
Volume Total	661	601	12			
Volume Left	3	0	5			
Volume Right	0	1	7			
cSH	976	1700	276			
Volume to Capacity	0.00	0.35	0.04			
Queue Length 95th (m)	0.1	0.0	1.0			
Control Delay (s)	0.1	0.0	18.6			
Lane LOS	A		C			
Approach Delay (s)	0.1	0.0	18.6			
Approach LOS			C			
Intersection Summary						
Average Delay			0.2			
Intersection Capacity Utilization		42.5%		ICU Level of Service		A
Analysis Period (min)			15			

HCM Unsignalized Intersection Capacity Analysis

15: Eagle St & east access

12/23/2020

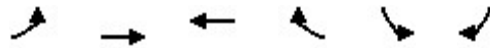

Movement	EBL	EBT	WBT	WBR	SBL	SBR
Lane Configurations		↑	↑			↑
Traffic Volume (veh/h)	0	611	543	2	0	10
Future Volume (Veh/h)	0	611	543	2	0	10
Sign Control		Free	Free		Stop	
Grade		0%	0%		0%	
Peak Hour Factor	0.92	0.92	0.92	0.92	0.92	0.92
Hourly flow rate (vph)	0	664	590	2	0	11
Pedestrians						
Lane Width (m)						
Walking Speed (m/s)						
Percent Blockage						
Right turn flare (veh)						
Median type		None	None			
Median storage (veh)						
Upstream signal (m)		397	321			
pX, platoon unblocked	0.91				0.92	0.91
vC, conflicting volume	592				1255	591
vC1, stage 1 conf vol						
vC2, stage 2 conf vol						
vCu, unblocked vol	505				1022	504
tC, single (s)	4.1				6.4	6.2
tC, 2 stage (s)						
tF (s)	2.2				3.5	3.3
p0 queue free %	100				100	98
cM capacity (veh/h)	967				242	518
Direction, Lane #	EB 1	WB 1	SB 1			
Volume Total	664	592	11			
Volume Left	0	0	0			
Volume Right	0	2	11			
cSH	1700	1700	518			
Volume to Capacity	0.39	0.35	0.02			
Queue Length 95th (m)	0.0	0.0	0.5			
Control Delay (s)	0.0	0.0	12.1			
Lane LOS			B			
Approach Delay (s)	0.0	0.0	12.1			
Approach LOS			B			
Intersection Summary						
Average Delay			0.1			
Intersection Capacity Utilization			37.3%	ICU Level of Service		A
Analysis Period (min)			15			

Queues

3: Yonge St & Eagle St W/Eagle St

12/23/2020

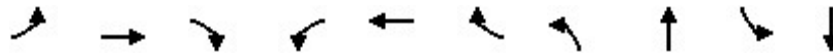

Lane Group	EBL	EBT	EBR	WBL	WBT	WBR	NBL	NBT	SBL	SBT
Lane Group Flow (vph)	65	313	237	166	365	120	153	1182	148	876
Act Effct Green (s)	26.4	29.4	26.4	44.1	43.6	43.6	17.5	46.0	17.3	45.9
Actuated g/C Ratio	0.21	0.23	0.21	0.35	0.35	0.35	0.14	0.37	0.14	0.37
v/c Ratio	0.29	0.69	0.46	0.66	0.54	0.19	0.60	0.88	0.58	0.65
Control Delay	46.1	52.5	11.4	44.2	36.6	6.5	62.9	46.7	62.4	36.7
Queue Delay	0.0	0.0	0.0	0.0	0.0	0.0	0.0	0.0	0.0	0.0
Total Delay	46.1	52.5	11.4	44.2	36.6	6.5	62.9	46.7	62.4	36.7
LOS	D	D	B	D	D	A	E	D	E	D
Approach Delay		36.0			33.0			48.6		40.4
Approach LOS		D			C			D		D
Queue Length 50th (m)	14.1	73.4	6.2	30.3	75.1	1.2	36.6	143.4	35.4	95.0
Queue Length 95th (m)	27.6	105.4	28.1	48.0	106.1	13.7	63.3	#208.3	61.4	132.3
Internal Link Dist (m)		212.4			146.8			184.0		260.3
Turn Bay Length (m)	171.0		52.0	120.0		55.0	85.0		110.0	
Base Capacity (vph)	311	620	632	250	839	777	298	1426	298	1439
Starvation Cap Reductn	0	0	0	0	0	0	0	0	0	0
Spillback Cap Reductn	0	0	0	0	0	0	0	0	0	0
Storage Cap Reductn	0	0	0	0	0	0	0	0	0	0
Reduced v/c Ratio	0.21	0.50	0.38	0.66	0.44	0.15	0.51	0.83	0.50	0.61

Intersection Summary

Cycle Length: 140

Actuated Cycle Length: 125.2

Control Type: Semi Act-Uncoord

Maximum v/c Ratio: 0.88

Intersection Signal Delay: 41.3

Intersection LOS: D

Intersection Capacity Utilization 84.3%

ICU Level of Service E

Analysis Period (min) 15

95th percentile volume exceeds capacity, queue may be longer.

Queue shown is maximum after two cycles.

HCM Signalized Intersection Capacity Analysis

3: Yonge St & Eagle St W/Eagle St

12/23/2020



Movement	EBL	EBT	EBR	WBL	WBT	WBR	NBL	NBT	NBR	SBL	SBT	SBR
Lane Configurations												
Traffic Volume (vph)	60	288	218	153	336	110	141	953	134	136	775	31
Future Volume (vph)	60	288	218	153	336	110	141	953	134	136	775	31
Ideal Flow (vphpl)	2000	2000	2000	2000	2000	2000	2000	2000	2000	2000	2000	2000
Total Lost time (s)	8.5	5.5	8.5	7.0	7.5	7.5	3.0	7.5		3.0	7.5	
Lane Util. Factor	1.00	1.00	1.00	1.00	1.00	1.00	1.00	0.95		1.00	0.95	
Frt	1.00	1.00	0.85	1.00	1.00	0.85	1.00	0.98		1.00	0.99	
Flt Protected	0.95	1.00	1.00	0.95	1.00	1.00	0.95	1.00		0.95	1.00	
Satd. Flow (prot)	1842	1939	1648	1842	1939	1648	1842	3616		1842	3663	
Flt Permitted	0.54	1.00	1.00	0.21	1.00	1.00	0.95	1.00		0.95	1.00	
Satd. Flow (perm)	1054	1939	1648	414	1939	1648	1842	3616		1842	3663	
Peak-hour factor, PHF	0.92	0.92	0.92	0.92	0.92	0.92	0.92	0.92	0.92	0.92	0.92	0.92
Adj. Flow (vph)	65	313	237	166	365	120	153	1036	146	148	842	34
RTOR Reduction (vph)	0	0	163	0	0	74	0	8	0	0	2	0
Lane Group Flow (vph)	65	313	74	166	365	46	153	1174	0	148	874	0
Turn Type	Perm	NA	Perm	pm+pt	NA	Perm	Prot	NA		Prot	NA	
Protected Phases		4		3	8		5	2		1	6	
Permitted Phases	4		4	8		8						
Actuated Green, G (s)	26.5	26.5	26.5	42.6	42.6	42.6	14.4	45.0		14.3	44.9	
Effective Green, g (s)	26.5	29.5	26.5	43.6	43.6	43.6	17.4	46.0		17.3	45.9	
Actuated g/C Ratio	0.21	0.24	0.21	0.35	0.35	0.35	0.14	0.37		0.14	0.37	
Clearance Time (s)	8.5	8.5	8.5	8.0	8.5	8.5	6.0	8.5		6.0	8.5	
Vehicle Extension (s)	3.0	3.0	3.0	3.0	3.0	3.0	3.0	3.0		3.0	3.0	
Lane Grp Cap (vph)	223	457	349	248	676	575	256	1331		255	1346	
v/s Ratio Prot		c0.16		0.05	c0.19		c0.08	c0.32		0.08	0.24	
v/s Ratio Perm	0.06		0.04	0.18		0.03						
v/c Ratio	0.29	0.68	0.21	0.67	0.54	0.08	0.60	0.88		0.58	0.65	
Uniform Delay, d1	41.3	43.5	40.6	31.3	32.6	27.2	50.5	36.9		50.4	32.8	
Progression Factor	1.00	1.00	1.00	1.00	1.00	1.00	1.00	1.00		1.00	1.00	
Incremental Delay, d2	0.7	4.2	0.3	6.7	0.8	0.1	3.7	7.2		3.3	1.1	
Delay (s)	42.0	47.7	40.9	38.0	33.4	27.3	54.2	44.1		53.7	33.9	
Level of Service	D	D	D	D	C	C	D	D		D	C	
Approach Delay (s)		44.5			33.5			45.3			36.8	
Approach LOS		D			C			D			D	

Intersection Summary

HCM 2000 Control Delay	40.6	HCM 2000 Level of Service	D
HCM 2000 Volume to Capacity ratio	0.77		
Actuated Cycle Length (s)	124.9	Sum of lost time (s)	23.0
Intersection Capacity Utilization	84.3%	ICU Level of Service	E
Analysis Period (min)	15		

c Critical Lane Group

HCM Unsignalized Intersection Capacity Analysis
6: Dixon Blvd & Eagle St

12/23/2020

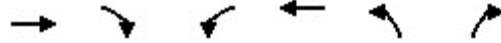

Movement	EBT	EBR	WBL	WBT	NBL	NBR
Lane Configurations	→	↘	↙	←	↘	↙
Traffic Volume (veh/h)	531	41	23	626	20	21
Future Volume (Veh/h)	531	41	23	626	20	21
Sign Control	Free			Free	Stop	
Grade	0%			0%	0%	
Peak Hour Factor	0.92	0.92	0.92	0.92	0.92	0.92
Hourly flow rate (vph)	577	45	25	680	22	23
Pedestrians						
Lane Width (m)						
Walking Speed (m/s)						
Percent Blockage						
Right turn flare (veh)						
Median type	None			None		
Median storage veh						
Upstream signal (m)	171					
pX, platoon unblocked			0.85		0.85	0.85
vC, conflicting volume			622		1330	600
vC1, stage 1 conf vol						
vC2, stage 2 conf vol						
vCu, unblocked vol			466		1299	439
tC, single (s)			4.1		6.4	6.2
tC, 2 stage (s)						
tF (s)			2.2		3.5	3.3
p0 queue free %			97		85	96
cM capacity (veh/h)			930		147	524
Direction, Lane #	EB 1	WB 1	NB 1			
Volume Total	622	705	45			
Volume Left	0	25	22			
Volume Right	45	0	23			
cSH	1700	930	233			
Volume to Capacity	0.37	0.03	0.19			
Queue Length 95th (m)	0.0	0.6	5.3			
Control Delay (s)	0.0	0.7	24.1			
Lane LOS			A	C		
Approach Delay (s)	0.0	0.7	24.1			
Approach LOS			C			
Intersection Summary						
Average Delay			1.2			
Intersection Capacity Utilization			59.0%	ICU Level of Service		B
Analysis Period (min)			15			

HCM Unsignalized Intersection Capacity Analysis

8: Donlin Ave & Eagle St

12/23/2020

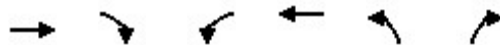

Movement	EBT	EBR	WBL	WBT	NBL	NBR
Lane Configurations						
Traffic Volume (veh/h)	645	3	4	590	5	1
Future Volume (Veh/h)	645	3	4	590	5	1
Sign Control	Free			Free	Stop	
Grade	0%			0%	0%	
Peak Hour Factor	0.92	0.92	0.92	0.92	0.92	0.92
Hourly flow rate (vph)	701	3	4	641	5	1
Pedestrians						
Lane Width (m)						
Walking Speed (m/s)						
Percent Blockage						
Right turn flare (veh)						
Median type	None			None		
Median storage veh						
Upstream signal (m)	230					
pX, platoon unblocked					0.78	
vC, conflicting volume			704	1352	702	
vC1, stage 1 conf vol						
vC2, stage 2 conf vol						
vCu, unblocked vol			704	1310	702	
tC, single (s)			4.1	6.4	6.2	
tC, 2 stage (s)						
tF (s)			2.2	3.5	3.3	
p0 queue free %			100	96	100	
cM capacity (veh/h)			894	136	438	
Direction, Lane #	EB 1	WB 1	NB 1			
Volume Total	704	645	6			
Volume Left	0	4	5			
Volume Right	3	0	1			
cSH	1700	894	154			
Volume to Capacity	0.41	0.00	0.04			
Queue Length 95th (m)	0.0	0.1	0.9			
Control Delay (s)	0.0	0.1	29.3			
Lane LOS			A	D		
Approach Delay (s)	0.0	0.1	29.3			
Approach LOS			D			
Intersection Summary						
Average Delay			0.2			
Intersection Capacity Utilization			42.5%	ICU Level of Service	A	
Analysis Period (min)			15			

Queues

10: sanford St/Carol Ave & Eagle St

12/23/2020

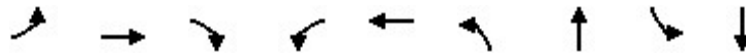

Lane Group	EBL	EBT	EBR	WBL	WBT	NBL	NBT	SBL	SBT
Lane Group Flow (vph)	36	626	71	112	691	68	192	43	137
Act Effect Green (s)	30.6	30.6	30.6	30.6	30.6	11.3	11.3	11.3	11.3
Actuated g/C Ratio	0.56	0.56	0.56	0.56	0.56	0.21	0.21	0.21	0.21
v/c Ratio	0.11	0.58	0.07	0.30	0.64	0.26	0.46	0.17	0.34
Control Delay	7.5	11.0	2.5	9.8	12.1	21.1	18.1	19.9	18.9
Queue Delay	0.0	0.0	0.0	0.0	0.0	0.0	0.0	0.0	0.0
Total Delay	7.5	11.0	2.5	9.8	12.1	21.1	18.1	19.9	18.9
LOS	A	B	A	A	B	C	B	B	B
Approach Delay		10.0			11.8		18.9		19.1
Approach LOS		A			B		B		B
Queue Length 50th (m)	1.4	33.3	0.2	4.8	38.4	5.6	12.0	3.5	10.0
Queue Length 95th (m)	5.8	70.9	4.6	15.6	82.5	14.9	28.0	10.5	23.1
Internal Link Dist (m)		206.0			73.5		168.7		142.5
Turn Bay Length (m)	83.0		32.0			55.0		58.0	
Base Capacity (vph)	344	1168	1019	402	1164	449	666	428	665
Starvation Cap Reductn	0	0	0	0	0	0	0	0	0
Spillback Cap Reductn	0	0	0	0	0	0	0	0	0
Storage Cap Reductn	0	0	0	0	0	0	0	0	0
Reduced v/c Ratio	0.10	0.54	0.07	0.28	0.59	0.15	0.29	0.10	0.21

Intersection Summary

Cycle Length: 65

Actuated Cycle Length: 54.9

Control Type: Semi Act-Uncoord

Maximum v/c Ratio: 0.64

Intersection Signal Delay: 12.7

Intersection LOS: B

Intersection Capacity Utilization 96.3%

ICU Level of Service F

Analysis Period (min) 15

HCM Signalized Intersection Capacity Analysis

10: sanford St/Carol Ave & Eagle St

12/23/2020



Movement	EBL	EBT	EBR	WBL	WBT	WBR	NBL	NBT	NBR	SBL	SBT	SBR
Lane Configurations												
Traffic Volume (vph)	33	576	65	103	617	18	63	107	70	40	102	24
Future Volume (vph)	33	576	65	103	617	18	63	107	70	40	102	24
Ideal Flow (vphpl)	2000	2000	2000	2000	2000	2000	2000	2000	2000	2000	2000	2000
Total Lost time (s)	7.0	7.0	7.0	7.0	7.0		6.0	6.0		6.0	6.0	
Lane Util. Factor	1.00	1.00	1.00	1.00	1.00		1.00	1.00		1.00	1.00	
Frt	1.00	1.00	0.85	1.00	1.00		1.00	0.94		1.00	0.97	
Flt Protected	0.95	1.00	1.00	0.95	1.00		0.95	1.00		0.95	1.00	
Satd. Flow (prot)	1842	1939	1648	1842	1931		1842	1824		1842	1884	
Flt Permitted	0.30	1.00	1.00	0.34	1.00		0.67	1.00		0.64	1.00	
Satd. Flow (perm)	573	1939	1648	667	1931		1298	1824		1235	1884	
Peak-hour factor, PHF	0.92	0.92	0.92	0.92	0.92	0.92	0.92	0.92	0.92	0.92	0.92	0.92
Adj. Flow (vph)	36	626	71	112	671	20	68	116	76	43	111	26
RTOR Reduction (vph)	0	0	29	0	1	0	0	41	0	0	14	0
Lane Group Flow (vph)	36	626	42	112	690	0	68	151	0	43	123	0
Turn Type	Perm	NA	Perm	Perm	NA		Perm	NA		Perm	NA	
Protected Phases		4			8			2			6	
Permitted Phases	4		4	8			2			6		
Actuated Green, G (s)	30.6	30.6	30.6	30.6	30.6		11.3	11.3		11.3	11.3	
Effective Green, g (s)	30.6	30.6	30.6	30.6	30.6		11.3	11.3		11.3	11.3	
Actuated g/C Ratio	0.56	0.56	0.56	0.56	0.56		0.21	0.21		0.21	0.21	
Clearance Time (s)	7.0	7.0	7.0	7.0	7.0		6.0	6.0		6.0	6.0	
Vehicle Extension (s)	3.0	3.0	3.0	3.0	3.0		3.0	3.0		3.0	3.0	
Lane Grp Cap (vph)	319	1080	918	371	1076		267	375		254	387	
v/s Ratio Prot		0.32			c0.36			c0.08			0.07	
v/s Ratio Perm	0.06		0.03	0.17			0.05			0.03		
v/c Ratio	0.11	0.58	0.05	0.30	0.64		0.25	0.40		0.17	0.32	
Uniform Delay, d1	5.7	7.9	5.5	6.5	8.4		18.3	18.9		17.9	18.5	
Progression Factor	1.00	1.00	1.00	1.00	1.00		1.00	1.00		1.00	1.00	
Incremental Delay, d2	0.2	0.8	0.0	0.5	1.3		0.5	0.7		0.3	0.5	
Delay (s)	5.9	8.7	5.5	6.9	9.7		18.8	19.6		18.3	19.0	
Level of Service	A	A	A	A	A		B	B		B	B	
Approach Delay (s)		8.3			9.3			19.4			18.8	
Approach LOS		A			A			B			B	

Intersection Summary

HCM 2000 Control Delay	11.1	HCM 2000 Level of Service	B
HCM 2000 Volume to Capacity ratio	0.58		
Actuated Cycle Length (s)	54.9	Sum of lost time (s)	13.0
Intersection Capacity Utilization	96.3%	ICU Level of Service	F
Analysis Period (min)	15		

c Critical Lane Group

HCM Unsignalized Intersection Capacity Analysis
 14: Eagle St & WEST ACCESS

12/23/2020

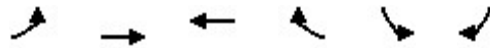

Movement	EBL	EBT	WBT	WBR	SBL	SBR
Lane Configurations						
Traffic Volume (veh/h)	12	590	644	5	4	5
Future Volume (Veh/h)	12	590	644	5	4	5
Sign Control		Free	Free		Stop	
Grade		0%	0%		0%	
Peak Hour Factor	0.92	0.92	0.92	0.92	0.92	0.92
Hourly flow rate (vph)	13	641	700	5	4	5
Pedestrians						
Lane Width (m)						
Walking Speed (m/s)						
Percent Blockage						
Right turn flare (veh)						
Median type		None	None			
Median storage (veh)						
Upstream signal (m)		209				
pX, platoon unblocked					0.86	
vC, conflicting volume	705				1370	702
vC1, stage 1 conf vol						
vC2, stage 2 conf vol						
vCu, unblocked vol	705				1348	702
tC, single (s)	4.1				6.4	6.2
tC, 2 stage (s)						
tF (s)	2.2				3.5	3.3
p0 queue free %	99				97	99
cM capacity (veh/h)	893				140	438
Direction, Lane #	EB 1	WB 1	SB 1			
Volume Total	654	705	9			
Volume Left	13	0	4			
Volume Right	0	5	5			
cSH	893	1700	226			
Volume to Capacity	0.01	0.41	0.04			
Queue Length 95th (m)	0.3	0.0	0.9			
Control Delay (s)	0.4	0.0	21.6			
Lane LOS	A		C			
Approach Delay (s)	0.4	0.0	21.6			
Approach LOS			C			
Intersection Summary						
Average Delay			0.3			
Intersection Capacity Utilization		48.6%		ICU Level of Service		A
Analysis Period (min)			15			

HCM Unsignalized Intersection Capacity Analysis

15: Eagle St & EAST ACCESS

12/23/2020

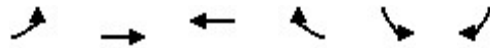

Movement	EBL	EBT	WBT	WBR	SBL	SBR
Lane Configurations		↑	↑			↑
Traffic Volume (veh/h)	0	648	583	7	0	5
Future Volume (Veh/h)	0	648	583	7	0	5
Sign Control		Free	Free		Stop	
Grade		0%	0%		0%	
Peak Hour Factor	0.92	0.92	0.92	0.92	0.92	0.92
Hourly flow rate (vph)	0	704	634	8	0	5
Pedestrians						
Lane Width (m)						
Walking Speed (m/s)						
Percent Blockage						
Right turn flare (veh)						
Median type		None	None			
Median storage (veh)						
Upstream signal (m)		367	275			
pX, platoon unblocked	0.80				0.86	0.80
vC, conflicting volume	642				1342	638
vC1, stage 1 conf vol						
vC2, stage 2 conf vol						
vCu, unblocked vol	424				977	419
tC, single (s)	4.1				6.4	6.2
tC, 2 stage (s)						
tF (s)	2.2				3.5	3.3
p0 queue free %	100				100	99
cM capacity (veh/h)	905				240	506
Direction, Lane #	EB 1	WB 1	SB 1			
Volume Total	704	642	5			
Volume Left	0	0	0			
Volume Right	0	8	5			
cSH	1700	1700	506			
Volume to Capacity	0.41	0.38	0.01			
Queue Length 95th (m)	0.0	0.0	0.2			
Control Delay (s)	0.0	0.0	12.2			
Lane LOS			B			
Approach Delay (s)	0.0	0.0	12.2			
Approach LOS			B			
Intersection Summary						
Average Delay			0.0			
Intersection Capacity Utilization			39.6%	ICU Level of Service		A
Analysis Period (min)			15			